

USER'S GUIDE

Vaisala DRYCAP® Dewpoint Transmitter DMT142



PUBLISHED BY

Vaisala Oyj
P.O. Box 26
FIN-00421 Helsinki
Finland

Phone (int.): +358 9 8949 1
Fax: +358 9 8949 2227

Visit our Internet pages at <http://www.vaisala.com/>

© Vaisala 2006

No part of this manual may be reproduced in any form or by any means, electronic or mechanical (including photocopying), nor may its contents be communicated to a third party without prior written permission of the copyright holder.

The contents are subject to change without prior notice.

Please observe that this manual does not create any legally binding obligations for Vaisala towards the customer or end user. All legally binding commitments and agreements are included exclusively in the applicable supply contract or Conditions of Sale.

Table of Contents

CHAPTER 1

GENERAL INFORMATION	5
About This Manual	5
Contents of This Manual	5
Version Information	6
Related Manuals	6
General Safety Considerations	7
Feedback.....	7
Product Related Safety Precautions	7
Recycling	8
Regulatory Compliances	8
Electromagnetic Compatibility.....	8
Trademarks	8
Warranty	9

CHAPTER 2

PRODUCT OVERVIEW	3
Introduction to Dewpoint Transmitter DMT142	3
The Basic Features and Options	3

CHAPTER 3

FUNCTIONAL DESCRIPTION	5
Advanced DRYCAP® Technology	5
Auto-Calibration	5
Sensor Purge	6
Sensor Warming in High Humidities	6

CHAPTER 4

INSTALLATION	7
Selecting Location	7
Wiring	9
Optional Connection Cable	10
Power Supply Requirements.....	11
Mounting	13
Direct Measurement in Process Pipeline	13
Sampling from Pressurized Processes	14
DMT242SC Sampling Cell	14
DMT242SC2 Sampling Cell with Swagelok	
Connectors	15
DSC74 Sampling Cell with Quick Connector and Leak	
Screw	15
DSC74B Two-Pressure Sampling Cell	17
DSC74C Two-Pressure Sampling Cell with Coil	18
DM240FA Duct Installation Flange	20

CHAPTER 5

SERIAL COMMANDS21

Connecting Serial Interface21

Commands for Basic Settings22

 Select Nonmetric Unit22

 Select Metric Unit22

 Scale Dewpoint Analog Output22

 Select Analog Output Quantity22

 Set Analog Output Mode23

 DMT142 Firmware Version Output.....23

 Pressure Compensation24

 Test Analog Output Current25

 Test Analog Voltage Output25

 Restart Program25

Serial Line Output Commands26

 Start Measurement Output26

 Stop Measurement Output26

 Set Output Interval.....26

Polling Mode for DMT142 Transmitter.....27

 Set Transmitter Address.....27

 Set Serial Interface Mode27

 OPEN Opening the Transmitter in POLL-State.....28

 SEND Outputting a Reading Once.....28

CHAPTER 6

MAINTENANCE.....29

Calibration and Adjustment.....29

Filter Change.....29

Vaisala Service Centers30

CHAPTER 7

TROUBLESHOOTING.....31

Error States31

Technical Support31

CHAPTER 8

TECHNICAL DATA33

Specifications33

Spare Parts and Accessories.....36

Dimensions in mm (inches).....37

Wiring Quick Reference37

List of Figures

Figure 1	Dewpoint Transmitter DMT142 Components.....	4
Figure 2	Mounting Dewpoint Transmitter DMT142	8
Figure 3	Wiring of Voltage Output Version.....	9
Figure 4	Wiring of Current Output Version	9
Figure 5	Pin Order of DMT142 Connector (Transmitter Side)	10
Figure 6	Snap-On Type Cable.....	11
Figure 7	Screw Fitting Type Cable	11
Figure 8	Example Of Sensor Purge Current (at Room Temperature with 24 VDC).....	12
Figure 9	Example of Auto-Calibration Current (at Room Temperature with 24 VDC)	12
Figure 10	DMT142 Installed Directly to Pipeline	13
Figure 11	DMT242SC Sampling Cell	14
Figure 12	DMT242SC2 Sampling Cell with Swagelok Connectors.....	15
Figure 13	DSC74 Sampling Cell with Accessories.....	16
Figure 14	DSC74B.....	17
Figure 15	Removing the Leak Screw	17
Figure 16	Default Assembly of DSC74C	18
Figure 17	Alternative Assembly of DSC74C (for Tight Spaces).....	19
Figure 18	DM240FA with DMT142	20
Figure 19	DMT142 Dewpoint Measurement Accuracy Graph	34
Figure 20	DMT142 Dimensions.....	37

List of Tables

Table 1	Manual Revisions	6
Table 2	Related Manuals	6
Table 3	Wiring Table	9
Table 4	Description of DMT142 Connection Cable.....	10
Table 5	DMT142 Serial Interface Setting	21
Table 6	Pressure Conversion Coefficients.....	24
Table 7	Measured Variable	33
Table 8	Operating Environment Specifications	34
Table 9	Output Specifications	34
Table 10	General Specifications	35

This page intentionally left blank.

CHAPTER 1

GENERAL INFORMATION

This chapter provides general notes for the manual and the product.

About This Manual

This manual provides information for installing, operating, and maintaining Dewpoint Transmitter DMT142.

Contents of This Manual

This manual consists of the following chapters:

- Chapter 1, General Information, provides general notes for the manual and the product.
- Chapter 2, Product Overview, introduces the features and advantages of Dewpoint Transmitter DMT142.
- Chapter 3, Functional Description, describes the advanced functionality of Dewpoint Transmitter DMT142, including the auto-calibration, sensor purge and sensor warming functions.
- Chapter 4, Installation, provides you with information that is intended to help you install Dewpoint Transmitter DMT142.

- Chapter 5, Serial Commands, contains the operating instructions for the serial interface of Dewpoint Transmitter DMT142.
- Chapter 6, Maintenance, provides information that is needed in basic maintenance of Dewpoint Transmitter DMT142, and contact information for Vaisala Service Centers.
- Chapter 7, Troubleshooting, describes the error states and provides contact information for technical support.
- Chapter 8, Technical Data, provides the technical data of Dewpoint Transmitter DMT142.

Version Information

Table 1 **Manual Revisions**

Manual Code	Description
M210397EN-A	Vaisala DRYCAP [®] Dewpoint Transmitter DMT142 Advanced User Manual, April 2003
M210397EN-B	Vaisala DRYCAP [®] Dewpoint Transmitter DMT142 User's Guide, October 2005 Td measurement and operating pressure range specification revised New sampling cell, installation flange and connection cable options added
M210397EN-C	Vaisala DRYCAP [®] Dewpoint Transmitter DMT142 User's Guide, March 2006; this manual Corrected wiring diagrams

Related Manuals

Table 2 **Related Manuals**

Manual Code	Manual Name
M210396EN-A	Vaisala DRYCAP [®] Dewpoint Transmitter DMT142 Quick Reference Guide

General Safety Considerations

Throughout the manual, important safety considerations are highlighted as follows:

WARNING

Warning alerts you to a serious hazard. If you do not read and follow instructions very carefully at this point, there is a risk of injury or even death.

CAUTION

Caution warns you of a potential hazard. If you do not read and follow instructions carefully at this point, the product could be damaged or important data could be lost.

NOTE

Note highlights important information on using the product.

Feedback

Vaisala Customer Documentation Team welcomes your comments and suggestions on the quality and usefulness of this publication. If you find errors or have other suggestions for improvement, please indicate the chapter, section, and page number. You can send comments to us by e-mail: manuals@vaisala.com

Product Related Safety Precautions

The Dewpoint Transmitter DMT142 delivered to you has been tested for safety and approved as shipped from the factory. Note the following precautions:

CAUTION

Do not modify the unit. Improper modification can damage the product or lead to malfunction.

Recycling



Recycle all applicable material.



Dispose of batteries and the unit according to statutory regulations.
Do not dispose of with regular household refuse.

Regulatory Compliances

Vaisala DRYCAP® Dewpoint Transmitter DMT142 complies with the following performance and environmental test standards:

Electromagnetic Compatibility

EN 61326-1:1997 + Am1:1998, Electrical equipment for measurement, control and laboratory use - EMC requirements - Industrial environment.

[CISPR16/22 Class B, EN/IEC 61000-4-2, EN/IEC 61000-4-3, EN/IEC 61000-4-4, EN/IEC 61000-4-5, EN/IEC 61000-4-6]

Trademarks

DRYCAP® is a registered trademark of Vaisala.

Warranty

Vaisala hereby represents and warrants all Products manufactured by Vaisala and sold hereunder to be free from defects in workmanship or material during a period of twelve (12) months from the date of delivery save for products for which a special warranty is given. If any Product proves however to be defective in workmanship or material within the period herein provided Vaisala undertakes to the exclusion of any other remedy to repair or at its own option replace the defective Product or part thereof free of charge and otherwise on the same conditions as for the original Product or part without extension to original warranty time. Defective parts replaced in accordance with this clause shall be placed at the disposal of Vaisala.

Vaisala also warrants the quality of all repair and service works performed by its employees to products sold by it. In case the repair or service works should appear inadequate or faulty and should this cause malfunction or nonfunction of the product to which the service was performed Vaisala shall at its free option either repair or have repaired or replace the product in question. The working hours used by employees of Vaisala for such repair or replacement shall be free of charge to the client. This service warranty shall be valid for a period of six (6) months from the date the service measures were completed.

This warranty is however subject to following conditions:

- a) A substantiated written claim as to any alleged defects shall have been received by Vaisala within thirty (30) days after the defect or fault became known or occurred, and
- b) The allegedly defective Product or part shall, should Vaisala so require, be sent to the works of Vaisala or to such other place as Vaisala may indicate in writing, freight and insurance prepaid and properly packed and labelled, unless Vaisala agrees to inspect and repair the Product or replace it on site.

This warranty does not however apply when the defect has been caused through

- a) normal wear and tear or accident;
- b) misuse or other unsuitable or unauthorized use of the Product or negligence or error in storing, maintaining or in handling the Product or any equipment thereof;
- c) wrong installation or assembly or failure to service the Product or otherwise follow Vaisala's service instructions including any repairs or installation or assembly or service made by unauthorized personnel not approved by Vaisala or replacements with parts not manufactured or supplied by Vaisala;
- d) modifications or changes of the Product as well as any adding to it without Vaisala's prior authorization;
- e) other factors depending on the Customer or a third party.

Notwithstanding the aforesaid Vaisala's liability under this clause shall not apply to any defects arising out of materials, designs or instructions provided by the Customer.

This warranty is expressly in lieu of and excludes all other conditions, warranties and liabilities, express or implied, whether under law, statute or otherwise, including without limitation any implied warranties of merchantability or fitness for a particular purpose and all other obligations and liabilities of Vaisala or its representatives with respect to any defect or deficiency applicable to or resulting directly or indirectly from the Products supplied hereunder, which obligations and liabilities are hereby expressly cancelled and waived. Vaisala's liability shall under no circumstances exceed the invoice price of any Product for which a warranty claim is made, nor shall Vaisala in any circumstances be liable for lost profits or other consequential loss whether direct or indirect or for special damages.

This page intentionally left blank.

CHAPTER 2

PRODUCT OVERVIEW

This chapter introduces the features and advantages of Dewpoint Transmitter DMT142.

Introduction to Dewpoint Transmitter DMT142

Vaisala DRYCAP[®] dewpoint transmitter DMT142 is designed for a wide range of OEM applications. The excellent stability and reliability of its performance is based on advanced DRYCAP[®] polymer sensor technology. The DRYCAP[®] technology has low maintenance needs due to its excellent long term stability and durability against condensation. The DMT142 transmitter is easy to install and the mechanics have been designed for harsh environments requiring protection against dust, dirt and splashed water.

The Basic Features and Options

- Small size to fit in tight installations.
- Analog outputs: 4 ... 20 mA or 0 - 1 V/0 - 5 V versions.
- Low maintenance requirements due to excellent long term stability.
- DRYCAP[®] polymer sensor with automatic auto-calibration and sensor purge ensures long term stability.
- Sensor warming keeps the sensor dry in abnormally high humidity situations.
- Field check suitability with DM70 hand-held meter.

- RS232 serial line connection for service use with DMT142RS cable.
- Optional sampling cells with different installation options available as DMT142 installation accessories.

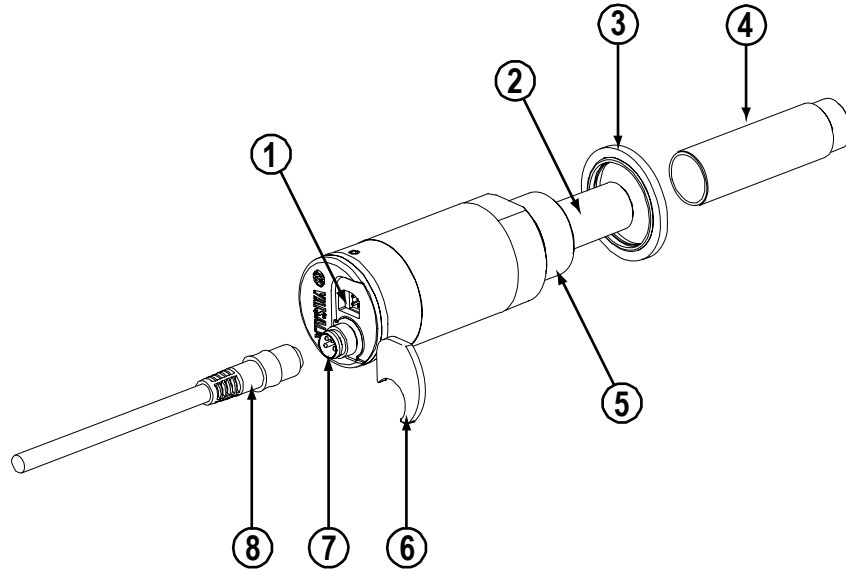

0507-093

Figure 1 Dewpoint Transmitter DMT142 Components

The following numbers refer to Figure 1 above:

- 1 = Serial line connector (for service use)
- 2 = DRYCAP[®] sensor protected with sintered filter
- 3 = Sealing washer
- 4 = Protective cap for probe
- 5 = G1/2" ISO 228/1
- 6 = Protection plug for serial line connector
- 7 = Cable connector
- 8 = Connection cable (optional)

CHAPTER 3

FUNCTIONAL DESCRIPTION

This chapter describes the advanced functionality of Dewpoint Transmitter DMT142, including the auto-calibration, sensor purge and sensor warming functions.

Advanced DRYCAP[®] Technology

Dewpoint Transmitter DMT142 utilizes an advanced, patented measurement technology to ensure accurate measurement with excellent long term stability. This results in very low maintenance requirements for the transmitter. The lasting performance is achieved with microprocessor technology and software that automatically performs self-diagnostic functions in addition to the normal dewpoint measurement. The self-diagnostic procedures that are conducted are called auto-calibration, sensor purge and sensor warming.

Auto-Calibration

The auto-calibration feature of the DMT142 transmitter is an automatic procedure which greatly reduces the possible drift in the dry end of the dewpoint measurement. It is performed at one hour intervals, and when the power is switched on. During auto-calibration the sensor is warmed for a short period (< 1 min) and the sensor capacitance values are evaluated at the elevated temperature. The possible dry end drift is then corrected to correspond to the calibrated values. During the auto-calibration the transmitter outputs the T_d value prior to the procedure.

Auto-calibration is carried out only if several criteria for the measurement environment are fulfilled. This ensures the reliability of the adjustments, and maintains the excellent long term stability that the patented technology offers. These criteria include for example a stable enough moisture level in the measured atmosphere. If the conditions are not fulfilled, the auto-calibration function is postponed until satisfactory conditions are reached.

Sensor Purge

Sensor purge is also an automatic procedure that minimizes the drift at the wet end readings of the dewpoint measurement. Sensor purge is performed once a day or when the power is switched on. The sensor is heated for several minutes which will then evaporate all excess molecules out of the sensor polymer. This, together with the auto-calibration results in a very small drift of the sensor due to the very linear behaviour of the polymer technology.

Sensor Warming in High Humidities

Additionally the DMT142 transmitter has a warming feature which prevents the sensor and filter from becoming wet in high humidities. High humidity may be present when the dewpoint temperature rises close to the gas temperature.

Sensor warming is switched on automatically when the humidity in the measured gas increases to a level where dew can start to form. The advantage of sensor warming is the rapid response of dewpoint measurement. A wet sensor and filter would otherwise result in a dewpoint equal to ambient temperature (that is RH = 100 %).

If in spite of sensor warming the sensor gets soaked, it will recover fully back to normal operation after it dries out.

CHAPTER 4

INSTALLATION

This chapter provides you with information that is intended to help you install Dewpoint Transmitter DMT142.

Selecting Location

In the mounting of Dewpoint Transmitter DMT142 it is important that the point of installation represents well the gas to be measured. Temperature changes do not affect the dewpoint measurement, but pressure changes will have an effect on the measurement. All leaks in the system must be eliminated to avoid ambient humidity affecting the measurement.

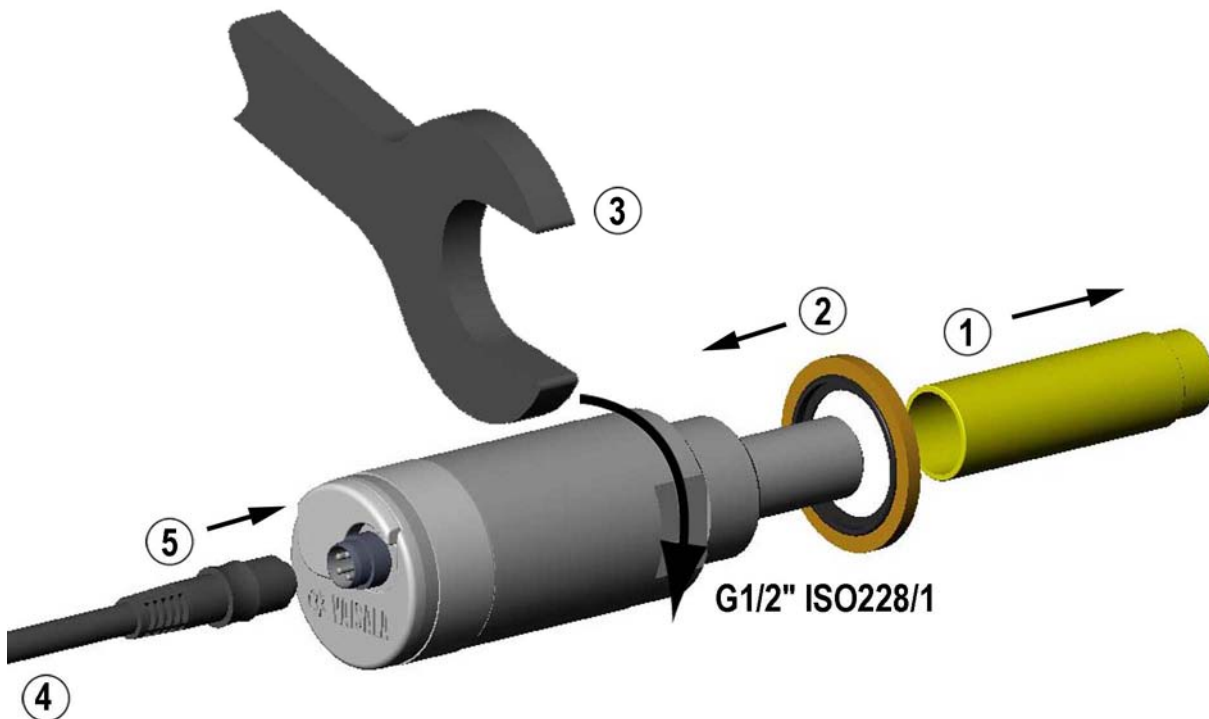

0507-094

Figure 2 **Mounting Dewpoint Transmitter DMT142**

The numbers in the following list refer to Figure 2 above:

1. Select a proper location to mount the DMT142 and remove the yellow sensor protective cap.
2. Fit the sealing washer onto the probe.
3. Mount the transmitter to the measurement point. The transmitter has parallel thread G1/2" ISO 228/1.
4. Connect the wires of the connection cable. When using the cable provided with DMT142 refer to the following wiring section. See the power supply requirements on page 11.
5. Plug in the cable to the transmitter and turn on the power supply.
6. Self diagnostics performed at start-up freeze the output during the first minutes of operation. Typical warm-up time is about 5 minutes before normal operation.

Wiring

Table 3 Wiring Table

Pin Number	Wire Colour (in supplied cables EN50044)	Name
1	Brown	+ VDC supply voltage
2	White	- analog output signal sense (voltage output versions only)
3	Blue	- VDC supply voltage
4	Black	+ analog output signal

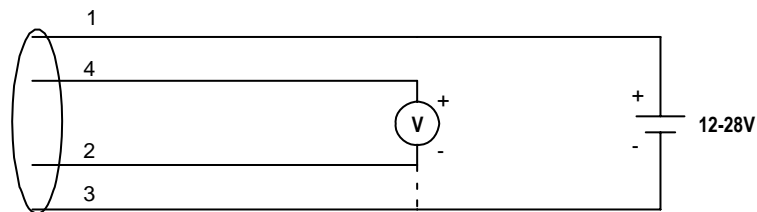

0507-095

Figure 3 Wiring of Voltage Output Version

The numbers below refer to Figure 3 above:

- 1 = Brown
- 2 = White
- 3 = Blue
- 4 = Black

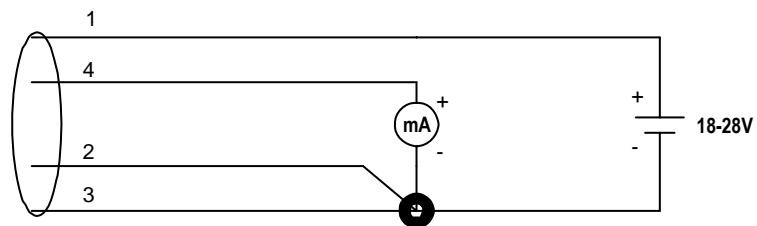

0507-096

Figure 4 Wiring of Current Output Version

Note the three wire connection. The numbers below refer to Figure 4 above:

- 1 = Brown
- 2 = White
- 3 = Blue
- 4 = Black

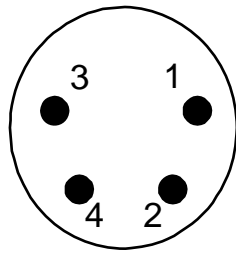

0507-097

Figure 5 Pin Order of DMT142 Connector (Transmitter Side)

Optional Connection Cable

DMT142 is delivered optionally with two types of connection cables, snap-on type or with screw fitting/locking.

Table 4 Description of DMT142 Connection Cable

Property	Description / Value
M8 Female, straight connector, molded sensor cable, IEC 60947-5-2	
Color	Black
Number of contacts	4
Conductors	0.25 mm ² (× 4) / 0.00039 inch ² (× 4)
Insulation	PVC
Cable diameter	5.0 mm / 0.2 inch
Protection class	IP67 / NEMA 4
Wire color code	EN50044
Snap-on type	
Cable length	2 m / 6.6 ft
Screw fitting type	
Shielded cable	0.3 m / 1 ft 3 m / 9.8 ft 5 m / 16.4 ft 10 m / 32.8 ft

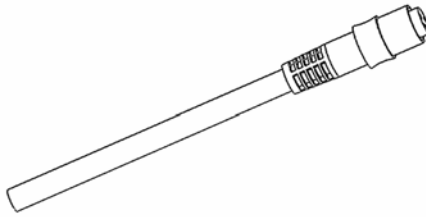

0510-036

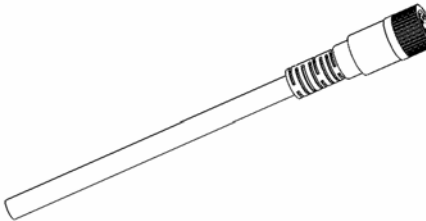
Figure 6 Snap-On Type Cable

0510-037

Figure 7 Screw Fitting Type Cable

Power Supply Requirements

The DMT142 transmitters are designed to operate with a supply voltage of 12 ... 28 VDC (voltage output version) or 18 ... 28 VDC (current output version).

When measuring in pressures 20 ... 50 bar_a (290 ... 725 psi_a) or temperatures -40 ... 0 °C (-40 ... 32 °F), a supply voltage of 24 ... 28 VDC is required.

The power supply should maintain the voltage for all load conditions.

Current consumption during normal operation is 10 mA. The consumption increases during the sensor self-diagnostics (auto-calibration and sensor purge). The maximum current consumption is 220 mA pulsed current (see the pictures on page 4).

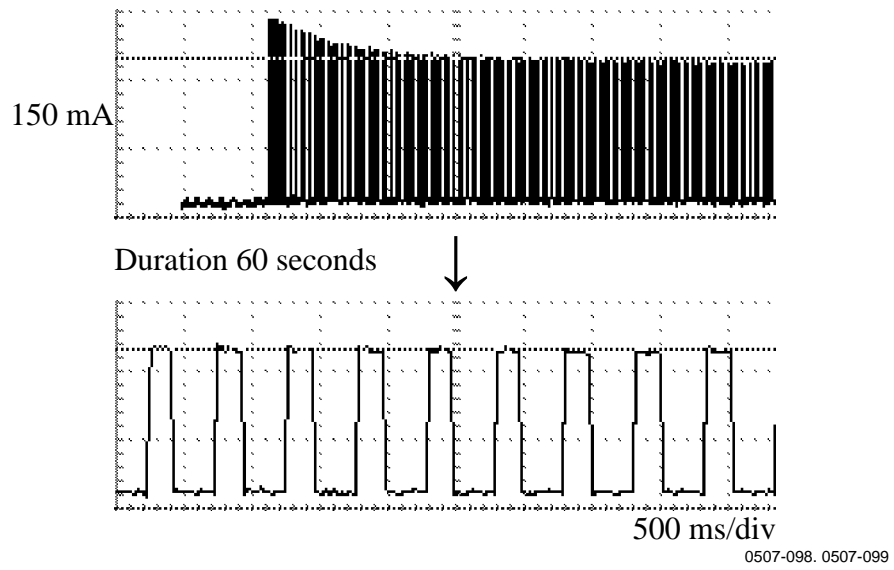

Figure 8 Example Of Sensor Purge Current (at Room Temperature with 24 VDC)

Typical duty cycle. Sensor purge current varies with supply voltage and operating temperature. The peak value is the highest in the lowest temperature.

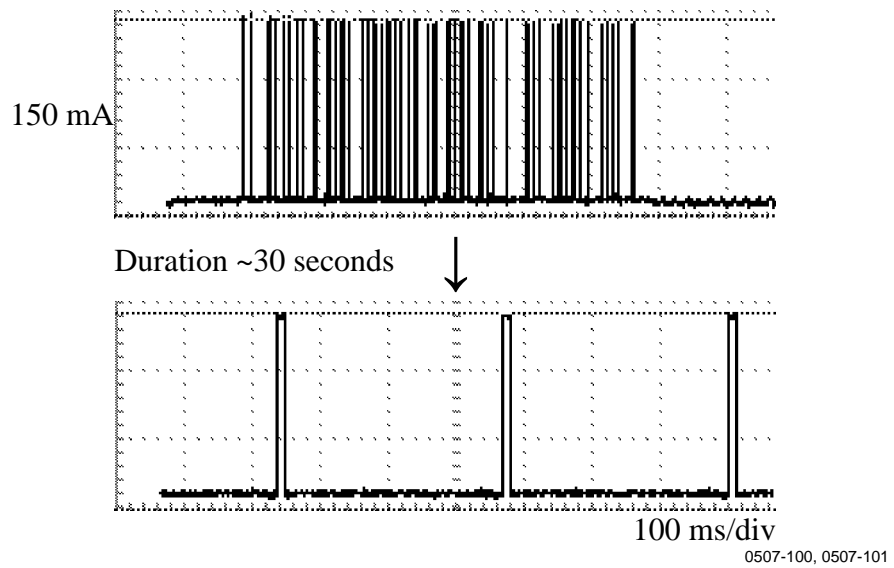

Figure 9 Example of Auto-Calibration Current (at Room Temperature with 24 VDC)

Typical duty cycle. Auto-calibration current varies with supply voltage and operating temperature.

Mounting

The recommended installation is directly to the measured gas pipeline, chamber etc. If the gas temperature is higher than the specified maximum operating temperature of the transmitter, gas sampling and cooling it to ambient temperature is recommended. Note that the dewpoint temperature must be clearly lower than the ambient temperature to avoid condensation in the sampling line. Sampling from the process is easy by using Vaisala sampling cell options.

Direct Measurement in Process Pipeline

Direct installation to the measured gas is the recommended installation method if the temperature of the gas is suitable for DMT142 and no additional filtering is needed due to very dusty or oily gas. Oil as such is not harmful for the DRYCAP[®] sensor, but response time may be slowed down if the sintered filter becomes clogged up with oil. The maximum measurement pressure is 50 bar_a / 725 psi_a (absolute pressure) for direct measurement.

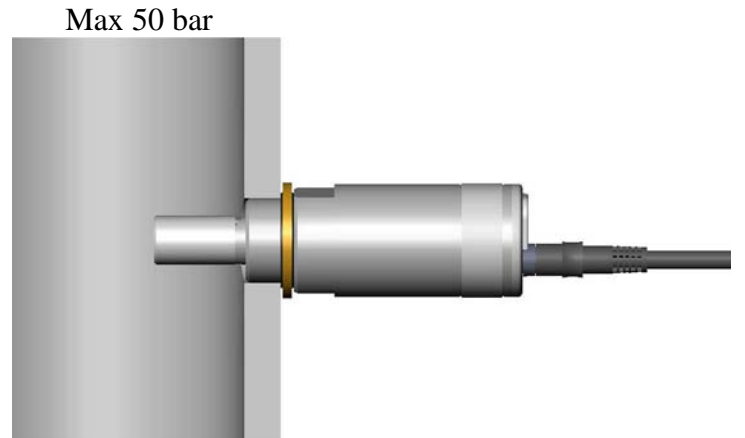

0507-102

Figure 10 DMT142 Installed Directly to Pipeline

In addition, due to the small size of DMT142 you can use a standard G1/2" T-shaped pipe fitting (not available from Vaisala) when installing DMT142 into a pipeline.

Sampling from Pressurized Processes

The maximum measurement pressure is 50 bar_a / 725 psi_a (absolute pressure) for sampling cell use. Pressure change between the process and sampling point will change the dewpoint temperature resulting in incorrect dewpoint reading. When sampling pressurized processes above 50 bar, the pressure must be regulated to 50 bar or below and the effect of the pressure difference between the process and the measurement cell must be taken into account in calculating the dewpoint.

The dewpoint measurement with the DRYCAP[®] sensor is not flow sensitive but the flow rate affects the response time. The optimal flow rate depends of the application but a minimum flow rate of 0.2 l/min is recommended.

The DMT142 is very light in weight which means that it can be installed in a sample pipeline in the sampling cells without the need of any additional mechanical support.

Five different sampling cell options and an installation flange are available.

DMT242SC Sampling Cell

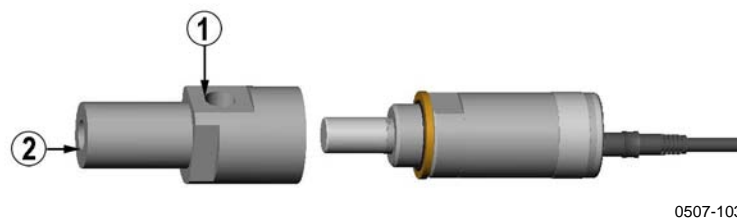

Figure 11 DMT242SC Sampling Cell

The following numbers refer to Figure 11 above:

- 1 = G1/4"
- 2 = G3/8"

DMT242SC is the basic sample cell with G3/8" ISO gas inlet thread and G1/4" ISO gas outlet thread.

DMT242SC2 Sampling Cell with Swagelok Connectors

DMT242SC2 is mechanically similar to DMT242SC but has welded Swagelok connectors for 1/4" tubing/pipeline. Welded connectors eliminate the possibility of leakage in the connectors.

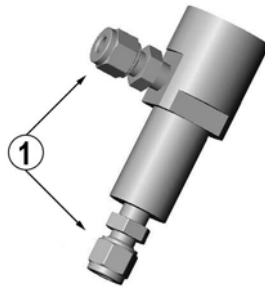

0507-104

Figure 12 DMT242SC2 Sampling Cell with Swagelok Connectors

The following number refers to Figure 12 above:

1 = Swagelok 1/4" connectors

DSC74 Sampling Cell with Quick Connector and Leak Screw

Vaisala DSC74 sampling cell allows quick and easy connection of the transmitter into pressurized processes. The quick connector allows the transmitter to be plugged in to the pipeline in seconds. The leak screw maintains the process pressure in the sampling cell but allows a small flow through the sampling cell. The DSC74 includes the following parts:

- DMT242SC sampling cell
- adjustable leak screw, thread 3/8"G
- quick connector (type D, NIP08, Quick 08)
- thread adapter, type male- male 3/8"G-1/2"G
- thread adapter, type male-female 3/8"G-1/4"G

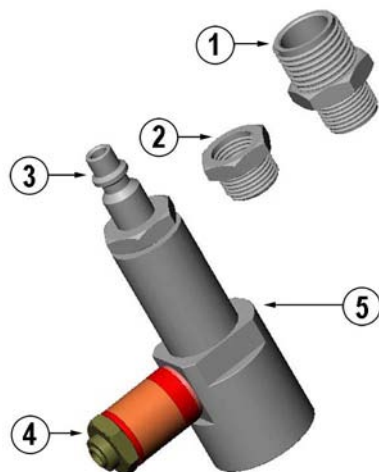

0507-105

Figure 13 DSC74 Sampling Cell with Accessories

The following numbers refer to Figure 13 above:

- 1 = Thread adapter type 3/8"G-1/2"G
- 2 = Thread adapter type 3/8"G-1/4"G
- 3 = Quick connector
- 4 = Leak screw
- 5 = Sampling cell DMT242SC

When using the DSC74, seal the threads of the quick connector or thread adapter carefully with PTFE thread seal tape. Tighten with a fork spanner. Ensure that the leaking screw of the sampling cell is open but not too much as to cause a pressure drop inside the sampling cell. Close the screw fully first, then turn 1/2 turn to open it.

DSC74B Two-Pressure Sampling Cell

The DSC74B can be used as the DSC74 for measurements in process pressure. DSC74B limits the flow rate with a leak screw. The maximum flow can also be increased by removing the leak screw and adjusting the flow manually with the valve. To remove the leak screw, see Figure 15 below.

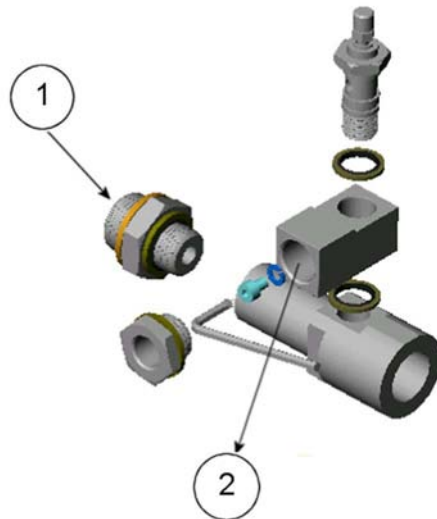

0510-032

Figure 14 DSC74B

The following numbers refer to Figure 14 above:

- 1 = Gas goes in
- 2 = Gas comes out



0510-033

Figure 15 Removing the Leak Screw

DSC74C Two-Pressure Sampling Cell with Coil

The DSC74C is mechanically like the DSC74B, but it is supplied with a coil for measurements in atmospheric pressure. The coil can also be used as a cooling coil for sampling from high temperature processes.

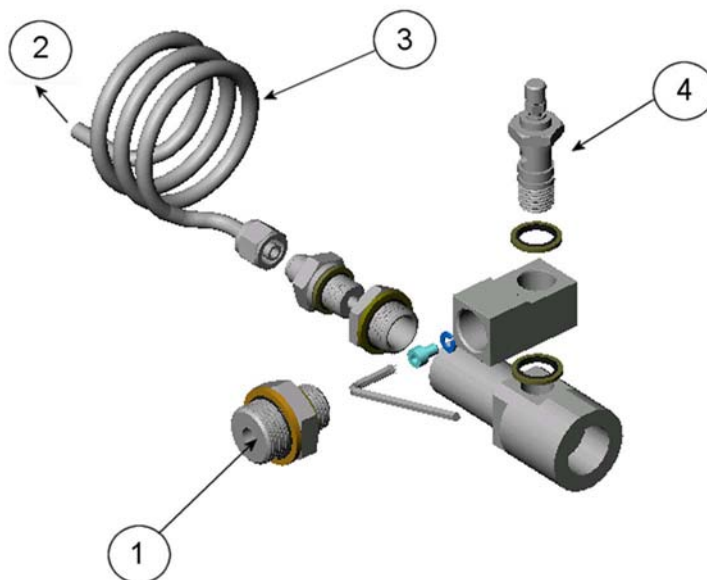

0510-034

Figure 16 Default Assembly of DSC74C

The following numbers refer to Figure 16 above:

- 1 = Gas goes in. Also the coil can be used here.
- 2 = Gas comes out
- 3 = Coil
- 4 = Valve

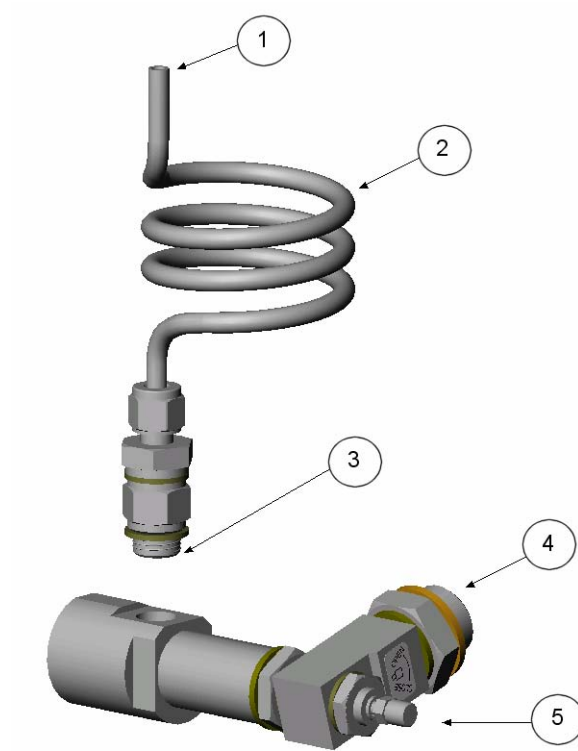

0403-113

Figure 17 Alternative Assembly of DSC74C (for Tight Spaces)

The following numbers refer to Figure 17 above:

- 1 = Gas comes out
- 2 = Coil
- 3 = Thread, max. size 7 mm
- 4 = Gas goes in
- 5 = Valve

The thread size cannot exceed 7 mm. Use the provided adapter to avoid damage to the probe.

DM240FA Duct Installation Flange

The transmitter can be installed directly in the process wall through DM240FA duct installation flange. When the probe is installed directly on the process wall or pipe, note that a closing valve may be needed on both sides of the installed probe so that the sensor head can be removed from the process for calibration or maintenance.

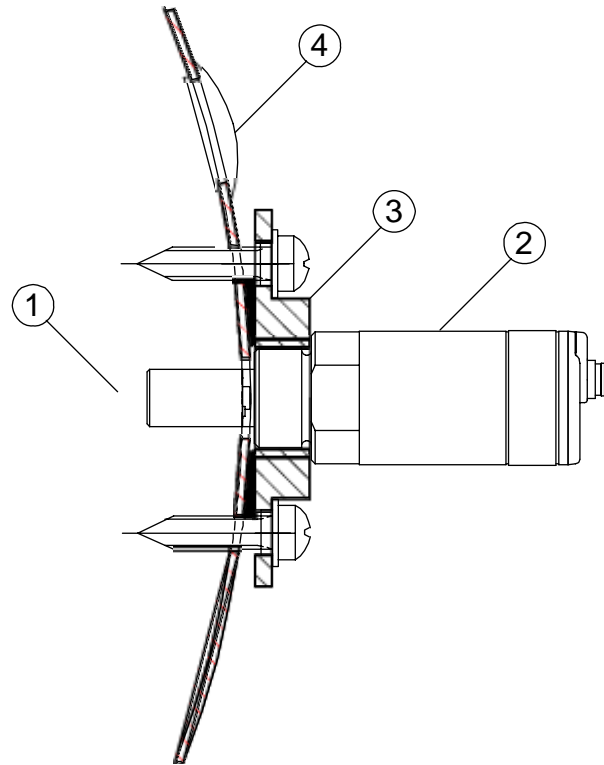

0510-035

Figure 18 DM240FA with DMT142

Numbers refer to Figure 18 above:

- 1 = Measured gas
- 2 = DMT142 transmitter
- 3 = DM240FA flange (thread G1/2" ISO)
- 4 = Recommended additional hole (plugged) for T_d field check reference measurement probe (for example, Vaisala DM70)

CHAPTER 5

SERIAL COMMANDS

This chapter contains the operating instructions for the serial interface of Dewpoint Transmitter DMT142.

Connecting Serial Interface

The use of the DMT142 via the serial bus requires a DMT142 serial interface cable (Vaisala order code: DMT142RS).

1. Connect the serial cable between your PC and DMT142 serial port.
2. Open the terminal program.
3. Set the serial settings, see the following table.

Table 5 DMT142 Serial Interface Setting

Property	Description / Value
Baud rate	2400
Parity	none
Data bits	8
Stop bits	1
Flow control	X _{on} /X _{off} (none)

The commands function as described when the serial interface is in full duplex mode. All commands can be issued either in upper or lower case letters.

The notation <cr> refers to pressing the carriage return (**Enter**) key on your computer keyboard.

Commands for Basic Settings

Select Nonmetric Unit

The DMT142 Transmitter outputs dewpoint temperature T_d in either Celsius or Fahrenheit degrees depending on the unit selection.

Syntax: UNIT n<cr>

Select Metric Unit

Syntax: UNIT m<cr>

Scale Dewpoint Analog Output

Syntax: ASCL x yy zz<cr>

where

x = 0 (zero)
yy = the lower limit of the scaling (given in °C or °F)
zz = the upper limit of the scaling (given in °C or °F)

Select Analog Output Quantity

Syntax: ASEL c zzz<cr>

where

c = channel number
zzz = channel output quantity = RH, ppm or T_D

Example:

```
>asel 0 rh
RH lo : -30.00 %RH
RH hi : 60.00 %RH
>
```

Set Analog Output Mode

The AMODE command can be used to change the analog output mode of the voltage output version of the transmitter between 0 ... 1 V and 0 ... 5 V modes. The analog output mode of a current output version of the transmitter is always 4 ... 20 mA.

Syntax: AMODE n0 n1<cr>

where

n0 = channel 0 analog output mode = 0 or 1

0 = 0 ... 1 V

1 = 0 ... 5 V

n1 = 0 (channel 1 analog output mode = always zero)

Example:

```
>amode 0 0
AMODE CH0: 0
AMODE CH1: 0
>
```

NOTE

Even though the software of the transmitter supports two channels, the transmitter only has one analog output channel (channel 0). The output mode of channel 1 is always set to 0 in the AMODE command syntax.

DMT142 Firmware Version Output

Syntax: VERS<cr>

Example:

```
>vers
DMTS142C / 1.01
>
```

Pressure Compensation

In pressurized environments, in order to optimize the accuracy of the DMT142, the actual process pressure can be set to the DMT142 if the pressure setting is not configured when ordering the product. In a worst case scenario, an incorrect pressure setting may result in an additional uncertainty of 1.5 °C in the dewpoint measurement. The worst case is considered to be the dewpoint temperature T_d at its lowest limit with the widest possible pressure setting difference.

Syntax: PRES pppp.pp<cr>

where

pppp.pp = absolute pressure (bar_a) in the measuring point

Example:

```
>pres 1.01325
Pressure      :    1.013
in use       :    1.013
>
```

The pressure conversion coefficients from other pressure units to bars is given in the table below.

Table 6 Pressure Conversion Coefficients

From	To bar_a
PaN/m ²	0.00001
mmHg torr	0.001333224
inHg	0.03386388
mmH ₂ O	0.00009806650
inH ₂ O	0.002490889
atm	1.01325
at	0.980665
psi _a	0.06894757

Example:

$$29.9213 \text{ inHg} = 29.9213 \times 0.03386388 = 1.01325 \text{ bar}_a$$

NOTE

Conversions from mmHg and inHg are defined at 0 °C and from mmH₂O and inH₂O at 4 °C.

Test Analog Output Current

The operation of the analog current output can be tested by forcing the output to a given value which can then be measured with a current meter from the analog output.

Syntax: ITEST aa.aaa x<cr>

where

aa.aaa = current (mA)
x = 0 (zero)

Example:

```
>itest 4.56 0
 4.56000      D78  0.00000      0
```

Test Analog Voltage Output

The operation of the analog voltage output can be tested by forcing the output to a given value which can then be measured with a voltage meter from the analog output.

Syntax: UTEST aa.aaa x<cr>

where

aa.aaa = voltage (V)
x = 0 (zero)

Example:

```
>utest 1.23 0
 1.23000      310  0.00000      0
```

Restart Program

Restarts the program. All changed settings stay in the memory after reset or power shutdown.

Syntax: RESET<cr>

Serial Line Output Commands

Start Measurement Output

The transmitter outputs continuous measurement values as an ASCII text string to the PC.

Syntax: R<cr>

Example:

```
>r
58.289   23.051   14.424
58.276   23.058   14.426
58.278   23.035   14.406
.         .         .
```

where

in the first column: relative humidity (%RH)

in the second column: ambient temperature (°C or °F)

in the third column: dewpoint (°C or °F)

Outputting the results continues in intervals issued with the command INTV. Stop the output with the command S.

Stop Measurement Output

Syntax: S<cr>

Set Output Interval

Syntax: INTV n xxx<cr>

where

n = time interval = 0 ... 255
xxx = time unit = "S", "MIN", or "H"

Example:

```
>INTV 10 MIN
Output interval:   10 MIN
>
```

The shortest output interval (with n = 0 [zero]) is approximately one second due to the internal measurement cycle.

Polling Mode for DMT142 Transmitter

The polling mode can be used when more than one transmitter is connected to one serial bus. When set to POLL state, the transmitters communicate one at a time when the specific transmitter address is called on the serial line.

Note that using the DMT142 serial output requires the DMT142RS serial line cable.

Set Transmitter Address

Syntax: ADDR n<cr>

where

n = address (0 ... 99)

Set Serial Interface Mode

Syntax: SMODE xxx<cr>

where

xxx = STOP, RUN, or POLL

In STOP mode: outputting only when command is issued, any command can be used.

In RUN mode: outputting automatically, only command S can be used

In POLL mode: outputting only with command SEND.

Examples:

```
>smode stop
Output mode : STOP
>

>smode run
Output mode : RUN
>

>smode poll
Output mode : POLL
>
```

OPEN Opening the Transmitter in POLL-State

Syntax: OPEN nn<cr>

where

nn = address (0 ... 99)

Resulting (only in POLL-state):

```
>DMT nn line opened for operator commands<CR>  
= ASCII 7 ( CTRL-G )
```

SEND Outputting a Reading Once

Syntax: SEND<cr>

Syntax in POLL-state: SEND nn<cr>

where

nn = address (0 ... 99)

CHAPTER 6

MAINTENANCE

This chapter provides information that is needed in basic maintenance of Dewpoint Transmitter DMT142, and contact information for Vaisala Service Centers.

Calibration and Adjustment

The DMT142 is fully calibrated as shipped from factory. The recommended calibration interval is 2 years. However, calibration should be done if there is a reason to believe that device is not within the accuracy specifications.

A simple field-checking operation can be performed by comparing the readings of the DMT142 and the DM70 hand-held dewpoint meter with a calibrated reference probe. For the comparison you need a connection cable, Vaisala order code: 211917ZZ.

If there is need for calibration or adjustment contact Vaisala Service Center or your local Vaisala representative.

Filter Change

The DRYCAP[®] sensor in the DMT142 transmitter is protected with a stainless steel sintered filter. The filtering grade is 34 µm.

The filter is recommended to be changed whenever it looks dirty or as a part of the periodical maintenance procedure. The recommended replacement interval depends heavily on the application and can vary from less than a year up to several years.

A dirty or corroded filter may cause increased response times. In case the DMT142 transmitter is used in a drying system with silica gel (or other drying agent) the dust from the dryer may collect on the sensor slowing the response but also generating a micro climate around the sensor altering the dewpoint at the sensor. This is easily corrected by changing or cleaning the filter.

CAUTION

Touching the sensor may damage it. Take special care to avoid touching the sensor when removing and replacing filters.

To replace the filter:

1. Unscrew the existing filter from the sensor head and remove it very carefully. Avoid touching the sensor.
2. Screw a new filter onto the sensor head.

Vaisala Service Centers

Send the device to Vaisala Instruments Service Centre for calibration and adjustment, see contact information below.

If the product needs repair, please contact Vaisala Instruments Service Center in your region. Follow the instructions given to you to speed up the process and to avoid extra costs.

NORTH AMERICAN SERVICE CENTER

Vaisala Inc., 10-D Gill Street, Woburn, MA 01801-1068, USA.

Phone: +1 781 933 4500, Fax: +1 781 933 8029

E-mail: us-customersupport@vaisala.com

EUROPEAN SERVICE CENTER

Vaisala Instruments Service, Vanha Nurmijärventie 21 FIN-01670 Vantaa, FINLAND.

Phone: +358 9 8949 2658, Fax: +358 9 8949 2295

E-mail: instruments.service@vaisala.com

TOKYO SERVICE CENTER

Vaisala KK, 42 Kagurazaka 6-Chome, Shinjuku-Ku, Tokyo 162-0825, JAPAN.

Phone: +81 3 3266 9617, Fax: +81 3 3266 9655

E-mail: aftersales.asia@vaisala.com

BEIJING SERVICE CENTER

Vaisala China Ltd., Floor 2 EAS Building, No. 21 Xiao Yun Road, Dongsanhuan Beilu, Chaoyang District, Beijing, P.R. CHINA 100027.

Phone: +86 10 8526 1199, Fax: +86 10 8526 1155

E-mail: china.service@vaisala.com

www.vaisala.com

CHAPTER 7

TROUBLESHOOTING

This chapter describes the error states and provides contact information for technical support.

Error States

- Analog 4-20 mA current output in error state: error state value for the analog current output is 0 mA.
- Analog voltage output in error state: error state value for the analog voltage output is 0V.
- Serial output in error state: serial line outputs asterisk characters (***) to indicate an error state.

In the case of an error, reset the transmitter by disconnecting the power or issuing the RESET command on the serial line. If the source of error is not found and the transmitter does not return to the normal state with the reset, please contact Vaisala Instruments Service or local Vaisala representative, see section Vaisala Service Centers on page 30.

Technical Support

For technical questions, contact the Vaisala technical support:

E-mail helpdesk@vaisala.com

Fax +358 9 8949 2790

This page intentionally left blank.

CHAPTER 8

TECHNICAL DATA

This chapter provides the technical data of Dewpoint Transmitter DMT142.

Specifications

Table 7 Measured Variable

Property	Description / Value
Dewpoint temperature	
Measurement range	-80 ... +60 °C (-112 ... +140 °F) T _d see graph on page 34
Standard version	-60 ... +60 °C (-76 ... +140 °F) T _d
Analog output scalings option 1 option 2 option 3	-80 ... +20 °C (-112 ... +68 °F) T _d -60 ... +40 °C (-76 ... +104 °F) T _d free scaling
Accuracy (-60 ... +60 °C / -76 ... +140 °F) Standard version (-50 ... +60 °C) When the dewpoint is below 0 °C (32 °F) the transmitter outputs frostpoint	± 3 °C (± 5.4 °F) T _d
Response time 63% [90%] at +20 °C gas temperature and 1 bar pressure -60 → -20 °C T _d (-76 → -4 °F T _d) -20 → -60 °C T _d (-4 → -76 °F T _d)	5 s [10 s] 45 s [10 min]
ppm volume concentration	
Measurement range	70 ... 200 000 ppm
Accuracy at +20 °C (+68 °F), 1013 mbar	7.3 ppm + 9.2 % of reading

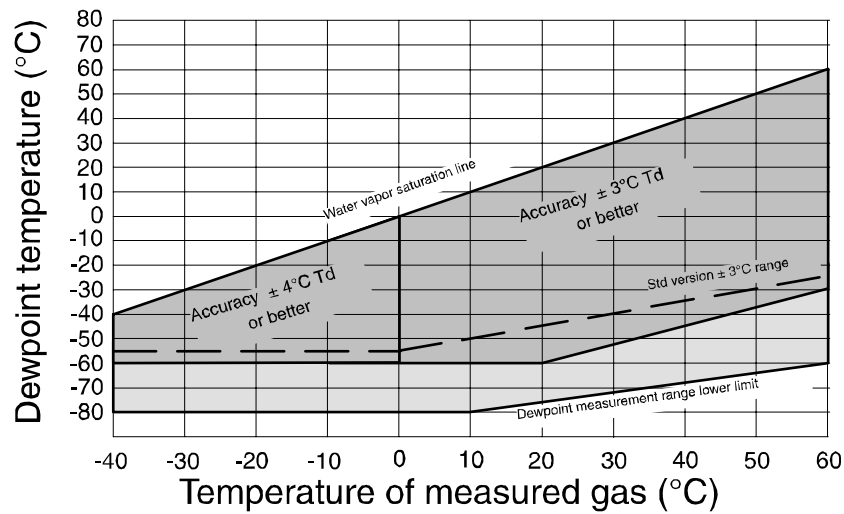

0610-073

Figure 19 DMT142 Dewpoint Measurement Accuracy Graph

Table 8 Operating Environment Specifications

Property	Description / Value
Temperature ¹⁾	0 ... +60 °C (+32 ... +140 °F)
Relative humidity	0 ... 100 %RH
Pressure ¹⁾	0 ... 50 bar _a (0 ... 725 psi _a)
Sample flow rate	no effect on measurement accuracy
Measured gases	noncorrosive gases

1) For extended temperature down to -40 °C (-40 °F) or pressure up to 50 bar_a (725 psi_a) the supply voltage must be 24 ... 28 VDC

Table 9 Output Specifications

Property	Description / Value
Analog output (scalable)	4 ... 20 mA (three-wire) 0 ... 1 V 0 ... 5 V
Resolution for current output	0.002 mA
Resolution for voltage output	0.3 mV
Typical temperature dependance	0.005 % of span/°C
Connector	4-pin M8 (IEC 60947-5-2) AERO AE65-221-FA35PN (DMT142 PALL OEM model) 2 m connection cable with snap-on or thread locking available
RS232 serial line for service use	with DMT142RS cable

Table 10 General Specifications

Property	Description / Value
Sensor	Vaisala DRYCAP®180D
Measured gases	noncorrosive gases (SF6 gas with special model)
Recommended calibration interval to confirm the specified accuracy	2 years
Operating voltage with current output with voltage output	18 ... 28 VDC 12 ... 28 VDC
Supply current during measurement during auto-calibration during sensor purge	10 mA + load current max 220 mA pulsed max 220 mA pulsed
Load for current output	max 500 Ω
Load for voltage output	min 10 kΩ
Housing material	stainless steel (AISI 316L) plastic cap (ABS/PC) stainless steel sintered filter (part no. DRW010335)
Mechanical connection	G1/2" ISO 228/1 thread with bonded seal ring (U-seal)
Housing classification	IP65 (NEMA 4)
Storage temperature range	-40 ... +80 °C (-40 ... +176 °F)
Weight	118 g (4.16 oz)

Spare Parts and Accessories

Order Code	Description
211598	M8 output cable 2 m with snap-on locking (IEC 60947-5-2)
HMP50Z032	Shielded M8 output cable 0.32 m with thread locking
HMP50Z300	Shielded M8 output cable 3 m with thread locking
HMP50Z500	Shielded M8 output cable 5 m with thread locking
HMP50Z1000	Shielded M8 output cable 10 m with thread locking
DMT142RS	RS232 serial line service cable
211917ZZ	Connection cable for DM70
DM240FA	Installation flange
DRW010335	Stainless steel sintered filter, 32 µm
Sampling cells	
DMT242SC	Sampling cell
DMT242SC2	Sampling cell with 1/4" Swagelok connectors
DSC74	Sampling cell with quick connector, leak screw and thread adapters
DSC74B	Two-pressure sampling cell
DSC74C	Two-pressure sampling cell with coil
DMCOIL	Separate cooling/venting coil for sampling cells

Dimensions in mm (inches)

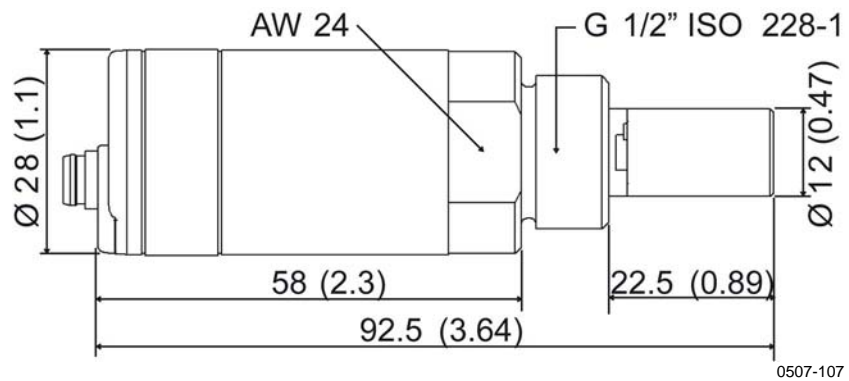
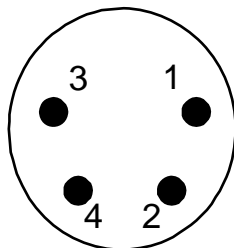

Figure 20 DMT142 Dimensions

Wiring Quick Reference

Wiring of the connector

- 1 = VDC supply + (brown)
- 2 = signal sense - (voltage output only) (white)
- 3 = VDC supply - (blue)
- 4 = signal + (black)



0507-097

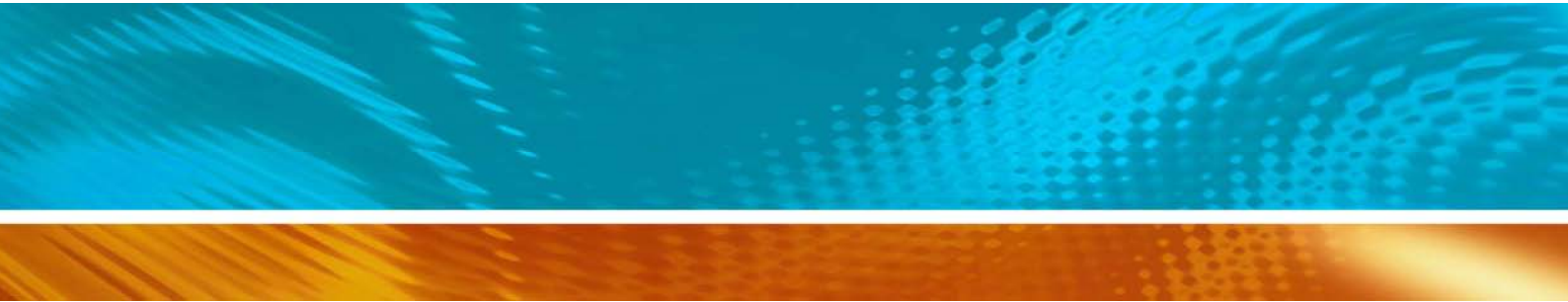

www.vaisala.com

