

# USER'S GUIDE

## Vaisala HUMICAP<sup>®</sup> Moisture and Temperature Transmitter for Oil MMT162



PUBLISHED BY

Vaisala Oyj  
P.O. Box 26  
FI-00421 Helsinki  
Finland

Phone (int.): +358 9 8949 1  
Fax: +358 9 8949 2227

Visit our Internet pages at <http://www.vaisala.com/>

© Vaisala 2009

No part of this manual may be reproduced in any form or by any means, electronic or mechanical (including photocopying), nor may its contents be communicated to a third party without prior written permission of the copyright holder.

The contents are subject to change without prior notice.

Please observe that this manual does not create any legally binding obligations for Vaisala towards the customer or end user. All legally binding commitments and agreements are included exclusively in the applicable supply contract or Conditions of Sale.

---

# Table of Contents

CHAPTER 1	
<b>GENERAL INFORMATION</b>	<b>5</b>
<b>About This Manual</b>	<b>5</b>
Contents of This Manual	5
Version Information	6
Related Manuals	6
General Safety Considerations	6
Feedback	6
<b>Product Related Safety Precautions</b>	<b>7</b>
<b>Recycling</b>	<b>7</b>
<b>Regulatory Compliances</b>	<b>7</b>
Electromagnetic Compatibility	7
<b>Trademarks</b>	<b>8</b>
<b>License Agreement</b>	<b>8</b>
<b>Warranty</b>	<b>8</b>
CHAPTER 2	
<b>PRODUCT OVERVIEW</b>	<b>9</b>
<b>Introduction to MMT162</b>	<b>9</b>
<b>Basic Features and Options</b>	<b>10</b>
<b>Transmitter Structure</b>	<b>10</b>
<b>Typical Applications</b>	<b>12</b>
Method Used for Measuring Moisture in Oil	12
Lubrication Oil	12
Transformer Oil	13
CHAPTER 3	
<b>INSTALLATION</b>	<b>15</b>
<b>Installing the Transmitter</b>	<b>15</b>
<b>Wiring</b>	<b>17</b>
Connection Cables	18
Power Supply Requirements	20
CHAPTER 4	
<b>OPERATION</b>	<b>21</b>
<b>Getting Started</b>	<b>21</b>
<b>Analog Output Operation Modes</b>	<b>21</b>
Normal Operation Mode and Malfunction Alarm	22
Limit Alarm	22
<b>Serial Communication</b>	<b>23</b>
Connecting to Serial Interface	23
Installing the Driver for the USB Cable	24
Terminal Program Settings	25

- List of Serial Commands .....27**
- Device Information and Status.....28**
  - Show Device Information .....28
  - Show Firmware Version .....28
- Configuring Serial Line Operation.....29**
  - Set Serial Line Settings .....29
  - Set Serial Line Response Time.....30
  - Set Transmitter Address.....30
  - Format Measurement Output .....30
  - Select Unit .....32
  - Set Serial Interface Mode.....32
- Configuring Measurement Parameters .....32**
  - Select Analog Output Quantity and Scaling .....32
  - Set Analog Output Mode (mA/V).....33
  - Calibrate Analog Output .....34
  - Set Malfunction Alarm Output for Analog Channels.....34
  - Set Alarm Limits for Analog Outputs / LED Indication.....35
  - Set Voltage for LED Alarm .....35
  - Extend Analog Output Range.....36
- Serial Line Output Commands .....36**
  - Start Measurement Output .....36
  - Stop Measurement Output .....36
  - Set Output Interval.....37
  - Output Reading Once.....37
- Troubleshooting Commands.....38**
  - Display the Currently Active Errors .....38
  - Test Analog Outputs.....38
- Other Commands .....39**
  - Opening the Transmitter in POLL Mode .....39
  - Closing the Connection to a Transmitter in POLL Mode.....39
  - Display Command List .....40
  - Reset Transmitter .....41
  - Restore Factory Settings.....41
- ppm Conversion .....41**
  - MMT162 ppm Conversion for Transformer Oils .....41
  - Conversion Model with Average Coefficients.....42
  - Conversion Model with Oil-specific Coefficients .....42
  - Setting Oil Coefficients Using Serial Line.....43
    - OIL.....43
  - Determination of Oil-Specific Coefficients.....43

CHAPTER 5

- MAINTENANCE.....47**
  - Cleaning.....47
  - Changing the Probe Filter.....48
  - Changing the Sensor .....48
  - Error States .....48
  - Technical Support .....49
  - Return Instructions .....49
  - Vaisala Service Centers .....50

CHAPTER 6

- CALIBRATION AND ADJUSTMENT .....51**

<b>MM70 in Checking and Adjusting</b> .....	<b>52</b>
<b>One-Point Relative Humidity Adjustment</b> .....	<b>52</b>
Using Serial Line .....	52
CRH .....	52
Using MI70 .....	53
<b>One-Point Temperature Adjustment</b> .....	<b>56</b>
Using Serial Line .....	56
CT .....	56
Using MI70 .....	57
<b>Analog Output Adjustment</b> .....	<b>58</b>

CHAPTER 7

<b>TECHNICAL DATA</b> .....	<b>59</b>
<b>Measured Values</b> .....	<b>59</b>
<b>Operating Environment</b> .....	<b>60</b>
<b>Inputs and Outputs</b> .....	<b>60</b>
<b>Mechanics</b> .....	<b>60</b>
<b>Spare Parts and Accessories</b> .....	<b>61</b>
<b>Dimensions in mm (inches)</b> .....	<b>62</b>

## List of Figures

Figure 1	Moisture and Temperature Transmitter for Oil MMT162.....	11
Figure 2	The Water Solubility of Transformer Oils versus Temperature	14
Figure 3	Removing the Transportation Protection Cap .....	15
Figure 4	Installing the Transmitter .....	16
Figure 5	Connecting the Cable.....	16
Figure 6	Connectors I and II .....	17
Figure 7	Connector Pinout.....	17
Figure 8	Cable with Snap-On Connector .....	18
Figure 9	Cable with Threaded Connector .....	18
Figure 10	Cable with 90° Angle Threaded Connector.....	19
Figure 11	LED Cable .....	19
Figure 12	USB Serial Interface Cable .....	20
Figure 13	PuTTY Terminal Application .....	26
Figure 14	Main Menu.....	53
Figure 15	Functions Menu .....	53
Figure 16	Metal Housing Transmitter Dimensions .....	62
Figure 17	Plastic Housing Transmitter Dimensions .....	63

## List of Tables

Table 1	Manual Revisions .....	6
Table 2	Related Manuals .....	6
Table 3	Quantities Measured and Calculated by MMT162.....	9
Table 4	Default Serial Interface Settings.....	23
Table 5	Serial Line Commands .....	27
Table 6	Modifiers .....	31
Table 7	Analog Output Modes.....	33
Table 8	Error Messages .....	49

This page intentionally left blank.

# CHAPTER 1

## GENERAL INFORMATION

This chapter provides general notes for the manual and the product.

### About This Manual

This manual provides information for installing, operating, and maintaining Vaisala HUMICAP<sup>®</sup> Moisture and Temperature Transmitter for Oil MMT162.

### Contents of This Manual

This manual consists of the following chapters:

- Chapter 1, General Information, provides general notes for the manual and the product.
- Chapter 2, Product Overview, introduces the features, advantages, and the product nomenclature
- Chapter 3, Installation, provides you with information that is intended to help you install the product.
- Chapter 4, Operation, provides information that is needed in basic maintenance of the product.
- Chapter 5, Maintenance, provides information that is needed in basic maintenance of the product.
- Chapter 6, Calibration and Adjustment, provides information that is needed in calibration and adjustment of the product.
- Chapter 7, Technical data, provides the technical data of the product.

## Version Information

**Table 1** Manual Revisions

Manual Code	Description
M210934EN-A	September 2008 - First version
M210934EN-B	March 2009 - Updated cable specification

## Related Manuals

**Table 2** Related Manuals

Manual Code	Manual Name
M210935EN-A	Vaisala HUMICAP <sup>®</sup> Moisture and Temperature Transmitter for Oil MMT162 Quick Reference Guide

## General Safety Considerations

Throughout the manual, important safety considerations are highlighted as follows:

**WARNING** Warning alerts you to a serious hazard. If you do not read and follow instructions very carefully at this point, there is a risk of injury or even death.

**CAUTION** Caution warns you of a potential hazard. If you do not read and follow instructions carefully at this point, the product could be damaged or important data could be lost.

**NOTE** Note highlights important information on using the product.

## Feedback

Vaisala Customer Documentation Team welcomes your comments and suggestions on the quality and usefulness of this publication. If you find errors or have other suggestions for improvement, please indicate the chapter, section, and page number. You can send comments to us by e-mail: [manuals@vaisala.com](mailto:manuals@vaisala.com)

## Product Related Safety Precautions

The Vaisala HUMICAP<sup>®</sup> Moisture and Temperature Transmitter for Oil MMT162 delivered to you has been tested for safety and approved as shipped from the factory. Note the following precautions:

**WARNING** Ground the product, and verify outdoor installation grounding periodically to minimize shock hazard.

**CAUTION** Do not modify the unit. Improper modification can damage the product or lead to malfunction.

## Recycling



Recycle all applicable material.



Dispose of batteries and the unit according to statutory regulations. Do not dispose of with regular household refuse.

## Regulatory Compliances

The Vaisala HUMICAP<sup>®</sup> Moisture and Temperature Transmitter for Oil MMT162 complies with the following performance and environmental test standards:

### Electromagnetic Compatibility

EN 61326-1:2006-04 + Am1:1998, Electrical equipment for measurement, control and laboratory use - EMC requirements - Industrial environment.

CISPR16/22 Class B, EN/IEC 61000-4-2, EN/IEC 61000-4-3, EN/IEC 61000-4-4, EN/IEC 61000-4-5, EN/IEC 61000-4-6

## Trademarks

HUMICAP<sup>®</sup> is a registered trademark of Vaisala Oyj.

Microsoft<sup>®</sup>, Windows<sup>®</sup>, Windows<sup>®</sup> 2000, Windows Server<sup>®</sup> 2003, Windows<sup>®</sup> XP, and Windows<sup>®</sup> Vista are registered trademarks of Microsoft Corporation in the United States and/or other countries.

## License Agreement

All rights to any software are held by Vaisala or third parties. The customer is allowed to use the software only to the extent that is provided by the applicable supply contract or Software License Agreement.

## Warranty

For certain products Vaisala normally gives a limited one-year warranty. Please observe that any such warranty may not be valid in case of damage due to normal wear and tear, exceptional operating conditions, negligent handling or installation, or unauthorized modifications. Please see the applicable supply contract or Conditions of Sale for details of the warranty for each product.

## CHAPTER 2

# PRODUCT OVERVIEW

This chapter introduces the features, advantages, and the product nomenclature of Moisture and Temperature Transmitter for Oil MMT162.

### Introduction to MMT162

The MMT162 transmitter is a microprocessor based instrument for the measurement of moisture in terms of water activity, for example in the lubrication of circulation systems or in transformer oil. The probe incorporates a capacitive thin film sensor. The operation of the sensor is based on changes in its capacitance as the thin polymer film absorbs water molecules.

The MMT162 transmitter is available with either metal or plastic housing. The transmitter can be configured in many ways: two analog output signals can be scaled, the measurement ranges can be changed within certain limits and there are two mechanical connection options, ISO and NPT 1/2. The MMT162 probe is supplied with a three or five meter connection cable.

The MMT162 also provides for accurate temperature measurement. It is an easy-to-install on-line probe which can be calibrated against, for example, traceable salt solutions.

**Table 3 Quantities Measured and Calculated by MMT162**

Quantity	Abbreviation	Metric Unit	Non Metric Unit
Water activity	$A_w$		
Temperature	T	°C	°F
Mass concentration of water in oil	ppm		

#### NOTE

ppm is only applicable to transformer oil.

Vaisala HUMICAP<sup>®</sup> Moisture and Temperature Transmitter for Oil MMT162 provides reliable moisture measurement in wide range of applications. Analog outputs can be chosen between current and voltage signals. Alternatively, digital output RS-485 comes as standard.

## Basic Features and Options

- Two analog outputs
- Digital output: RS-485
- USB connectivity for service connections via the optional USB M8 cable
- Different cable lengths available
- Available with two different thread options: ISO G1/2" and NPT 1/2"
- Low maintenance requirements due to excellent long term stability
- LED cable option that enables a visual alarm function
- Field calibration possible with MM70
- Two filter types available: stainless steel grid filter and high flow stainless steel grid filter (>> 1 m/s)

## Transmitter Structure

The structure of the MMT162 is shown in Figure 1 on page 11. The transmitter body does not have user serviceable parts inside, and is not designed to be opened. Opening the transmitter will void the warranty.

When the transmitter is delivered, the filter is protected by a yellow transport protection cap. Remove the transport protection cap before installing the transmitter.

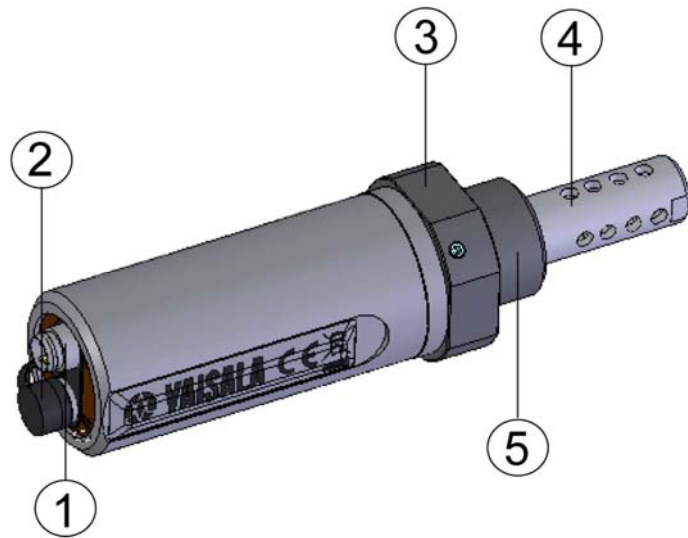

0805-007

**Figure 1** Moisture and Temperature Transmitter for Oil  
MMT162

where

- 1 = 4-pin M8 connector I: analog output channels and operating power
- 2 = 4-pin M8 connector II (shown with protective cap): digital output (RS-485) and operating power
- 3 = 30 mm nut
- 4 = HUMICAP<sup>®</sup> sensor protected with stainless steel grid filter
- 5 = Connection thread: ISO G1/2" or NPT 1/2"

## Typical Applications

### Method Used for Measuring Moisture in Oil

The MMT162 transmitter measures water in oil in terms of water activity (aw) which can be determined as follows: water activity indicates the amount of water on the scale of 0 - 1 aw. In this scale, 0 aw is an indication of completely water free oil and 1 aw an indication of oil fully saturated with water. Water is present in free form.

The most important feature which distinguishes the measurement of water activity (aw) from the traditional measurement of absolute water content (in ppm) is that the saturation point remains stable regardless of the oil type or the aging of oil, additives used etc. As water activity exceeds 0.9 aw in any system, there is a risk for segregation (especially if the temperature decreases).

The water activity is used for alarming at the point of  $>0.9$  aw that the risk for free water in the system is obvious. The most important advantages of this system are the fact that water activity is immune to the aging of oil and to additives, and that the MMT162 transmitter can be used for continuous on-line measurements. In addition, the MMT162 can be calibrated against salt solutions and no reference oils are needed.

**NOTE**

To avoid self-heating of the probe and consequential measurement errors, make sure there is some flow in the application process.

### Lubrication Oil

In many industrial plants, like paper mills, hydro power plants and off-shore wind turbines, there is a certain amount of free moisture constantly present. This means that there is a high risk of the free moisture becoming into contact with the machine bearings. The most common reasons for the entrance of water are inadequate sealing of the housing or moisture absorption from ambient air. Accidental leakages from oil coolers and other equipment can also cause damage.

Free water in lubrication oil prevents oil from forming a uniform layer on the metal surfaces and thus deteriorating its lubrication properties. This can cause, for example, spot heating, cavitation, corrosion and micro pitting. Free water also ruins additives like AW (antiwear) and EP (extreme pressure). Note that bearings should never be exposed to oils

that have high water content; this is also important during standstill because the risk for corrosion increases as the oil temperature decreases. It is essential to monitor the water content and to keep it on a suitable level, meaning below saturation.

When measuring the water content of oil, it is best to measure the water activity before an oil reservoir and from a pressure line flow. This way the performance of dehumidifiers can be kept under control to ensure that no free water reaches the bearings.

## Transformer Oil

The determination of moisture in oil is an essential part of a comprehensive transformer maintenance program. Aging and deterioration increase the capacity of oil to absorb water. The primary interest in transformers is to measure the water not in oil but in the cellulosic insulation around the transformer windings. Heating and cooling have a considerable effect on moisture levels in oil. While temperature raises, the paper insulation of transformers tends to loose moisture which is absorbed by the oil surrounding it. Saturation level is thus a true indicator of moisture present. The MMT162 method provides for a reliable detection of the aging of oil and possible leakages.

Oil immersed transformers rely on the oil for cooling, protection from corrosion and as an important component of their insulation. Excessive moisture contents in oil causes accelerated ageing of the insulation materials and reduces their dielectric strength. In extreme cases this can result in arcing and short circuits within the windings. Accurate moisture measurements can also warn about leaks in the oil system, as water is absorbed from the surrounding air.

Heating and cooling of a transformer effect moisture levels in oil. This is due to the fact that the water solubility of oil is temperature dependent. In general, water solubility increases as temperature raises, see Figure 2 on page 14 below. Changes in temperature affect also on water desorption of the paper insulation around the transformer windings. Desorption of water from the insulation increases as temperature raises and the surrounded oil absorbs desorbed water. Moisture level in oil is thus a true indicator of moisture present in the paper insulation.

In addition, it must be noted that capacity of oil to absorb water depends both on the chemical structure of the oil and the additives.

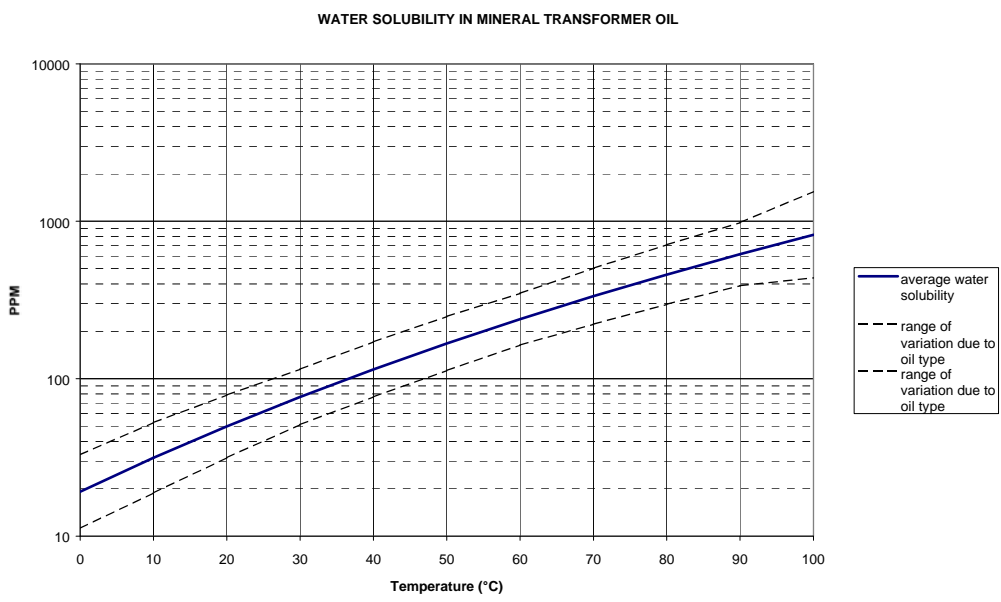

0510-029

**Figure 2 The Water Solubility of Transformer Oils versus Temperature**

The margins show the range of variation of water solubility found in mineral oils.

## CHAPTER 3

# INSTALLATION

This chapter provides you with information that is intended to help you install the product.

## Installing the Transmitter

After selecting a suitable measurement location, follow the procedure below to install the transmitter:

1. Remove the yellow transport protection cap from the transmitter.



0805-005

**Figure 3** Removing the Transportation Protection Cap

2. Prepare the sealing of the connection:
  - If the transmitter has a parallel ISO G1/2" thread, place the sealing ring at the base of the thread. Always use a new sealing ring; do not re-use a previously installed one.
  - If the transmitter has an NPT 1/2" thread, do not use the sealing ring. Instead, apply PTFE tape or suitable paste sealant to the thread. Follow the application instructions of the sealant.
3. Make sure that the threads on the mounting point are of the correct type, and fasten the transmitter to the measurement point. Use your hands to turn the probe until it feels tight. Do not use force at this point, and check that the sealing ring (if used) remains centered.

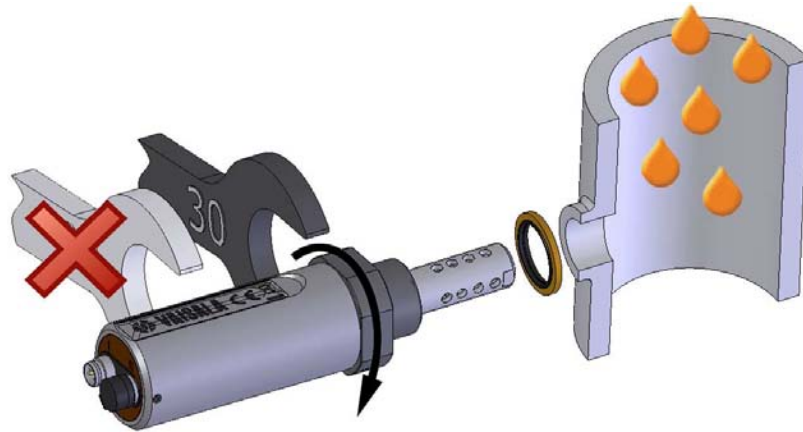

0805-006

**Figure 4 Installing the Transmitter**

4. Use a 30 mm wrench to tighten the connection to 25 Nm, as shown in Figure 4 above. If you do not have a 30 mm wrench, use a 1 3/16" wrench or an adjustable wrench instead.

**CAUTION**

Only tighten the probe from the 30 mm nut. Do NOT apply force to other points in the probe body.

5. Connect the wires of the connection cable.

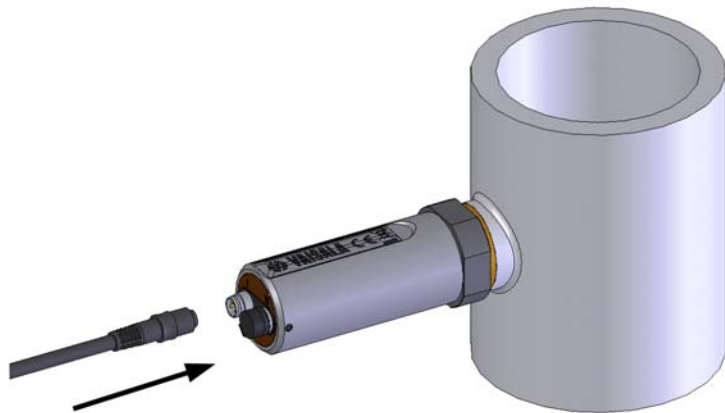

0710-130

**Figure 5 Connecting the Cable**

6. Plug in the cable to the transmitter. Be sure to use the correct connector; refer to section Wiring on page 17.
7. Cover the unused connector on the transmitter with the rubber plug that is attached to the transmitter.

# Wiring

Pin	I	II	Wire Colour
1	Vcc	Vcc	Brown
2	Analog output 1	RS-485 B	White
3	GND	GND	Blue
4	Analog output 2 / LED	RS-485 A	Black

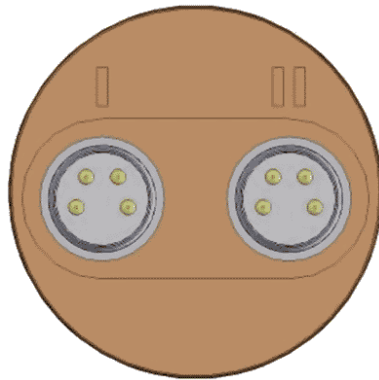

0707-035

**Figure 6** Connectors I and II

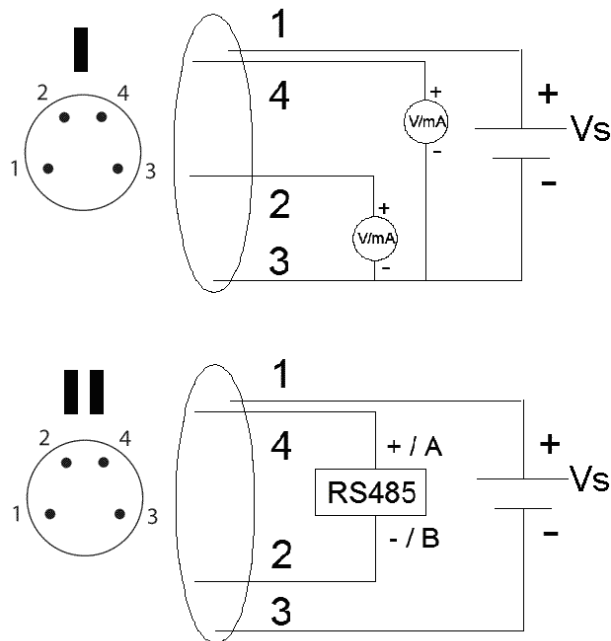

0707-036

**Figure 7** Connector Pinout

## Connection Cables

The following connection cable options are available for MMT162:

- Unshielded cable with M8 female straight snap-on connector
- Shielded cables with M8 female straight threaded connector
- Shielded cables with M8 female 90° angle threaded connector
- LED cable
- USB serial interface cable

Figure 8, Figure 9, Figure 12 and Figure 10 below show the different cable options that are available.

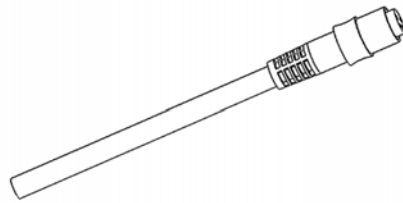

0510-036

**Figure 8** Cable with Snap-On Connector

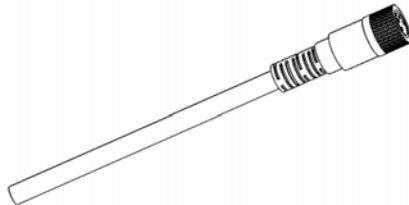

0510-037

**Figure 9** Cable with Threaded Connector



0809-004

**Figure 10** Cable with 90° Angle Threaded Connector



0809-003

**Figure 11** LED Cable



0809-002

**Figure 12**     **USB Serial Interface Cable**

For the cable order codes, see section Spare Parts and Accessories on page 61.

## Power Supply Requirements

The MMT162 transmitters are designed to operate with a supply voltage of 14 ... 24 VDC.

The power supply should maintain the voltage for all load conditions. Current consumption during normal measurement is 20 mA + load current. For more specific information, see chapter Technical data on page 59.

## CHAPTER 4

# OPERATION

This chapter contains information that is needed to operate this product.

## Getting Started

MMT162 is ready to be used once it has been connected to a power source.

## Analog Output Operation Modes

The MMT162 has two analog output channels. These channels can function in two different modes, which can be set individually for both channels:

1. Normal operation mode
2. Limit alarm mode

When the transmitter is ordered from Vaisala, the modes are configured as specified in the order form. You can change the operation settings after delivery by using serial commands and the USB cable accessory.

## Normal Operation Mode and Malfunction Alarm

In the normal operation mode, a channel outputs voltage or current that corresponds to the reading of the selected quantity.

If the transmitter is malfunctioning, the channel output is set to a pre-defined level. This level can be changed using the **AERR** command; see page 34.

**NOTE**

The malfunction alarm overrides the limit alarm mode. If the transmitter is malfunctioning, the analog outputs are always set to the levels specified with the **AERR** command.

## Limit Alarm

The limit alarm is activated when the measured quantity goes below the low limit, or above the high limit. The alarm levels and limits are configurable using the **ALARM** command (see page 35). By default, the alarm levels are set as follows:

- For **current output**, an active alarm is indicated by the current being at the maximum of the scale (20 mA).
- For **voltage output**, an active alarm is indicated by the voltage being at the maximum of the selected scale. For example, if the voltage output scale is 0 ... 5 V, an output of 5 V indicates the alarm is active.
- For **LED alarm**, an active alarm is indicated by a lit LED. When the alarm status is low, the LED is not lit. If the transmitter is malfunctioning or it cannot measure for some reason, this causes the LED to blink at 0.5 Hz frequency.

LED alarm indicator is integrated to a LED cable (Vaisala item MP300LEDCBL) that can be ordered and used instead of a regular connection cable.

# Serial Communication

## Connecting to Serial Interface

The MMT162 can be connected to a PC using the RS-485 line, for example using the USB serial connection cable (Vaisala item 219690). The cable also provides operation power to the transmitter from the USB port. It is OK to connect the USB serial connection cable even if the transmitter is already supplied with operation power from another cable.

To connect to serial interface:

1. If you have not used the MMT162 USB serial connection cable before, install the driver that came with the cable. Refer to section Installing the Driver for the USB Cable on page 24 for detailed instructions.
2. Connect the USB serial connection cable between your PC and the RS-485 port of the MMT162 (port II).
3. Open the terminal program (e.g. PuTTY in Microsoft Windows®).
4. Set the serial settings of the terminal program, and open the connection. See the following table.

**Table 4** Default Serial Interface Settings

Property	Description / Value
Baud rate	19200
Parity	none
Data bits	8
Stop bits	1

**NOTE**

In case the transmitter starts up in an error state, the serial interface settings are automatically returned to the default settings given in Table 4 above.

## Installing the Driver for the USB Cable

Before taking the USB cable into use, you must install the provided USB driver on your PC. When installing the driver, you must acknowledge any security prompts that may appear. The driver is compatible with Windows® 2000, Windows® XP, Windows Server® 2003, and Windows® Vista.

1. Check that the USB cable is not connected. Disconnect the cable if you have already connected it.
2. Insert the media that came with the cable, or download the driver from [www.vaisala.com](http://www.vaisala.com).
3. Execute the USB driver installation program (setup.exe), and accept the installation defaults. The installation of the driver may take several minutes.
4. After the driver has been installed, connect the USB cable to a USB port on your PC. Windows will detect the new device, and use the driver automatically.
5. The installation has reserved a COM port for the cable. Verify the port number, and the status of the cable, using the **Vaisala USB Instrument Finder** program that has been installed in the Windows Start menu.

Windows will recognize each individual cable as a different device, and reserve a new COM port. Remember to use the correct port in the settings of your terminal program. If you are using the Vaisala MI70 Link application, you do not need to check the COM port, as the MI70 Link detects the USB connection automatically.

There is no reason to uninstall the driver for normal use. However, if you wish to remove the driver files and all Vaisala USB cable devices, you can do so by uninstalling the entry for **Vaisala USB Instrument Driver** from the **Add or Remove Programs (Programs and Features in Windows Vista)** in the Windows Control Panel.

## Terminal Program Settings

The default settings of the MMT162 serial interface are presented in Table 4 on page 23. If the settings of your MMT162 have been changed and you do not know what they are, refer to section Restore Factory Settings on page 41.

The steps below describe how to connect to the MMT162 using the PuTTY terminal application for Windows (available for download at [www.vaisala.com](http://www.vaisala.com)) and a USB serial interface cable:

1. Connect the USB serial interface cable between your PC and the RS-485 port of the MMT162 (port II).
2. Start the PuTTY application.
3. Select the **Serial** settings category, and check that the correct COM port is selected in the **Serial line to connect to** field.

Note: You can check which port the USB cable is using with the **Vaisala USB Instrument Finder program** that has been installed in the Windows Start menu.

4. Check that the other serial settings are correct for your connection, and change if necessary. **Flow control** should be set to **None** unless you have a reason to change it.
5. Click the **Open** button to open the connection window and start using the serial line.

Note: If PuTTY is unable to open the serial port you selected, it will show you an error message instead. If this happens, restart PuTTY and check the settings.

6. You may need to adjust the **Local echo** setting in the **Terminal** category to see what you are typing on the serial line. To access the configuration screen while a session is running, click the right mouse button over the session window, and select **Change Settings...** from the pop-up menu.

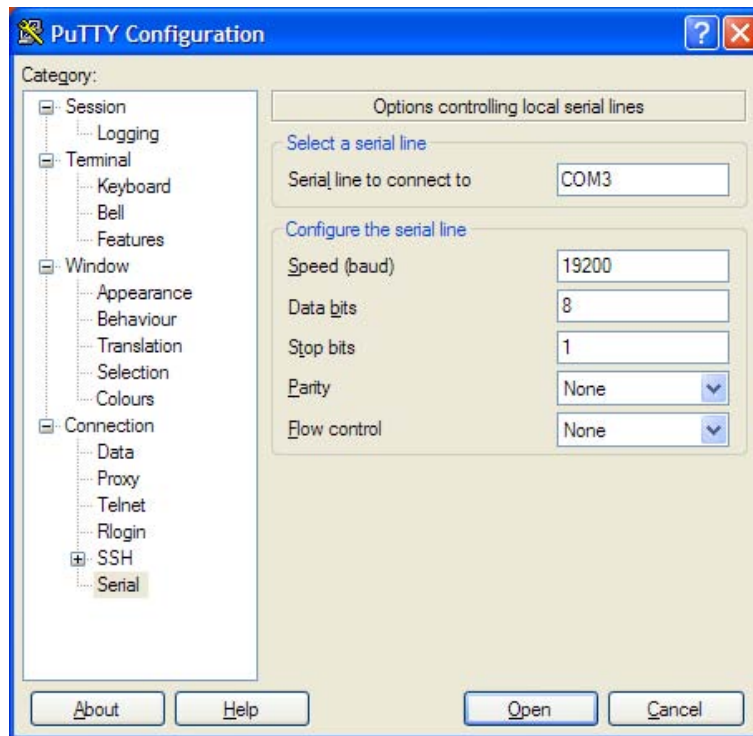

0807-004

**Figure 13 PuTTY Terminal Application**

## List of Serial Commands

The **bold** text in the brackets is the default setting. To issue a command, type it on your computer and press the **Enter** key.

**Table 5 Serial Line Commands**

<b>Command</b>	<b>Description</b>
?	Output information about the device
??	Output information about the device in POLL mode
ACAL	Analog output calibration
ADDR [ <b>0</b> ... 99]	Set the transmitter address (for POLL mode)
AERR	Change the analog error output values
ALARM	Set analog output limit alarm modes
AMODE	View the analog output modes
AOVER [ON/OFF]	Allow analog outputs to exceed their range 10%
ASEL	Select the parameters for the analog outputs
ATEST	Set and display current output values
CLOSE	Close the temporary connection (Back to POLL mode)
CRH	Relative humidity calibration
CT	Temperature calibration
ERRS	List present transmitter errors
FORM	Set the output format of SEND and R commands
FRESTORE	Restore factory settings
HELP	List the most common commands
INTV [ <b>0</b> ... 255 S/MIN/H]	Set the continuous output interval (for RUN mode)
LED	Set voltage for LED alarm
OIL	Display oil parameters
OILI	Set new oil parameters
OPEN [ <b>0</b> ... 99]	Open a temporary connection to a POLL mode device
R	Start the continuous outputting
RESET	Reset the transmitter
S	Stop the continuous outputting
SDELAY	View or set user port (RS-485) answer minimum delay
SEND [0 ... 99]	Output the reading once
SERI [baud p d s]	User Port settings (Default: 4800 E 7 1) baud: 300 ... 115200
SMODE [ <b>STOP</b> /RUN/POLL]	Set the serial interface mode
UNIT [M/N]	Select the metric or non-metric output units
VERS	Display the software version information

## Device Information and Status

### Show Device Information

The `?` command outputs a listing of device information. If you wish to display the listing for all devices on the current serial line, issue the command `??`.

`?<cr>`

`??<cr>`

#### Example:

```
>?  
MMT162 0.92  
Serial number : G0000002  
Batch number  : D0720012  
Module number  : ?????????  
Sensor number  : C6010000  
Sensor model   : Humicap L2  
Cal. date      : YYYYMMDD  
Cal. info      : NONE  
Time           : 00:21:19  
Serial mode    :      STOP  
Baud P D S    :      4800 E 7 1  
Output interval:      2 S  
Serial delay   :      0  
Address        :      0  
Pressure       :      1.0132 bar  
Filter         :      0.800  
Ch1 output     : 0 ... 20 mA  
Ch2 output     : 0 ... 20 mA  
Ch0 error out  :      0.000 mA  
Ch1 error out  :      0.000 mA  
Ch0 aw lo     :      0.00  
Ch0 aw hi     :      1.00  
Ch1 T lo      :     -20.00 'C  
Ch1 T hi      :      80.00 'C
```

### Show Firmware Version

Use the **VERS** command to display software version information.

#### Example:

```
vers  
MMT162 1.02
```

# Configuring Serial Line Operation

## Set Serial Line Settings

Use the serial line command **SERI** [*b p d s*] to set communication settings for the user port.

**SERI** [*b p d s*]

where

- b = Bit rate (110, 150, 300, 600, 1200, 2400, 4800, 9600, 19200, 38400)
- p = Parity (n = none, e = even, o = odd)
- d = Data bits (7 or 8)
- s = Stop bits (1 or 2)

### Example:

```
>SERI 600 N 8 1
600 N 8 1
>
```

You need to reset the transmitter to activate the new communication settings set with the **SERI** command.

The settings can be changed one parameter at a time or all parameters at once:

```
>SERI O                                changing parity only
4800 O 7 1
>SERI 600 N 8 1                          changing all parameters
600 N 8 1
>
```

You can use the **SERI** command to change/view the user port settings even if you are currently connected to the service port.

## Set Serial Line Response Time

With the **SDELAY** command, you can set delay (response time) for user port RS-485, or view currently set delay value. Value corresponds to tens of milliseconds (for example 5 = 0.050 s minimum answer delay). The value can be set between 0...255.

### Example:

```
>sdelay
Serial delay   : 0 ? 10
```

```
>sdelay
Serial delay   : 10 ?
```

## Set Transmitter Address

Addresses are required only for POLL mode (see Set Serial Interface Mode on page 32). Use the **ADDR** command to input the RS-485 transmitter address.

### **ADDR** [*aa*]

where

*aa* = address (0 ... 99) (default = 0)

**Example:** the transmitter is configured to address 99.

```
>ADDR
Address : 2 ? 99
>
```

## Format Measurement Output

Use the serial line command **FORM** to change the format or select a certain quantities for the output commands **SEND** and **R**.

### **FORM** [*x*]

where

*x* = Formatter string

Formatter string consists of quantities and modifiers. The MMT162 measures the following quantities:

- water activity (aw)
- temperature (T) (metric unit: °C, non metric unit:°F)
- ppm for transformer oil only (H<sub>2</sub>O)

When selecting the quantity, use the abbreviations of the quantities. The modifiers are presented in Table 6 on page 31 below.

**Table 6 Modifiers**

Modifier	Description
x.y	Length modifier (number of digits and decimal places)
#t	Tabulator
#r	Carriage-return
#n	Line feed
"	String constant
#xxx	Special character, code "xxx" (decimal), for example #027 for ESC
U5	Unit field and length (optional)

**Example:**

```
>form "aw=" 6.4 aw #t "t=" 6.2 t #r#n
1>
```

```
>send
aw=      0.2644   t=      25.50
>
```

```
>form "Oil ppm= " h2o " " u3 #r#n
>send
Oil ppm=      16.6 ppm
>
```

Command **FORM /** will return the default output format. The default output format depends on the device configuration.

```
>form /
>send
aw=      0.087 T= 24.0 'C
>
```

## Select Unit

Use the **UNIT** command to select metric or non-metric output units.

**UNIT** [*x*]

where

*x* = M or N

where

M = Metric units

N = Non-metric units

## Set Serial Interface Mode

Use the **SMODE** command to set the default serial interface mode.

**SMODE** [*xxxx*]

where

*xxxx* = STOP, RUN or POLL

In STOP mode: measurements output only by command SEND, all commands can be used

In RUN mode: outputting automatically, only command S can be used to stop.

In POLL mode: measurements output only with command SEND [*addr*].

When several transmitters are connected to the same line, each transmitter must be entered an own address in the initial configuration, and POLL mode must be used.

## Configuring Measurement Parameters

### Select Analog Output Quantity and Scaling

Select and scale the quantities for the analog outputs with the **ASEL** command. Note that the optional quantities can be selected only if they have been selected when ordering the device.

**ASEL** [xxx yyy]

where

xxx = Quantity of channel 1  
 yyy = Quantity of channel 2

Always enter all the quantities for all outputs. The MMT162 measures the following quantities:

- water activity (aw)
- temperature (T) (metric unit: °C, non metric unit: °F)
- ppm for transformer oil only (H<sub>2</sub>O)

**Example:**

```

asel
Ch0 aw lo : 0.00 ?
Ch0 aw hi : 1.00 ?
Ch1 T lo : -20.00 'C ?
Ch1 T hi : 80.00 'C ?

```

## Set Analog Output Mode (mA/V)

The **AMODE** command can be used to change the analog output mode of channels 1 and 2. When used without parameters it displays the current settings and with parameters new settings can be set. The available parameters are listed in Table 7 on page 33 below.

**Table 7** Analog Output Modes

Parameter	Output mode
1	0 ... 20 mA
2	4 ... 20 mA
3	0 ... 1 V
4	0 ... 5 V
5	0 ... 10 V
6	LED alarm
7	Current alarm
8	Voltage alarm

**Example:**

```

amode 1 2
Ch1 output : 0 ... 20 mA
Ch2 output : 4 ... 20 mA

```

## Calibrate Analog Output

Use the **ACAL** command to adjust analog output channels. To adjust channel 1, use parameter 1 and to adjust channel 2, use parameter 2 as in the example below.

After entering the **ACAL** command, use a calibrated current/voltage meter to measure the output, and enter the values.

**Example** (current outputs):

```
acal 1
Ch1    U1 ( V ) ? 1.001
Ch1    U2 ( V ) ? 9.011
acal 2
Ch2    U1 ( V ) ? 0.0988
Ch2    U2 ( V ) ? 0.8997
```

## Set Malfunction Alarm Output for Analog Channels

Use the **AERR** command to set the analog output levels that are output in case of a device malfunction. The default output level is 0.

**AERR**

**Example:**

```
aerr
Ch1 error out : 10.000V ? 0
Ch2 error out : 1.000V ? 0
```

**NOTE**

The error output value must be within a valid range of the output mode.

**NOTE**

The error output value is displayed only when there are minor electrical faults such as a humidity sensor damage. When there is a severe device malfunction, the error output value is not necessarily shown.

## Set Alarm Limits for Analog Outputs / LED Indication

Use the **ALARM** command to set the analog output alarm limits and quantities. For an explanation of the alarm limits, see section Limit Alarm on page 22.

**ALARM**<cr>

Before setting the alarm limits, verify the currently set analog output modes using the **AMODE** command.

The following example shows that a high limit alarm has been enabled for channel 2. If the measured value rises above the limit ( 0.90 a<sub>w</sub>), an error is reported. If you are using a LED cable, the LED lights up to indicate an error state.

### Example:

```
alarm ?
Channel 1:
Low Limit      :      OFF
High Limit     :      OFF
Aerr           :      ON
Quantity       :      T
Limit Lo       :      15.00
Limit Hi       :      30.00
Hysteresis     :      0.50
Level Lo       :      0.20
Level Hi       :      0.80
Channel 2:
Low Limit      :      OFF
High Limit     :      ON
Aerr           :      OFF
Quantity       :      aw
Limit Lo       :      0.10
Limit Hi       :      0.90
Hysteresis     :      0.01
Level Lo       :      0.20
Level Hi       :      0.80
```

## Set Voltage for LED Alarm

With the **LED** command, you can set a different voltage level for each channel.

### Example:

```
led ?
Ch 1 Led Voltage :      2.80 V
Ch 2 Led Voltage :      2.80 V
```

## Extend Analog Output Range

Use the **AOVER** command to allow the analog output channels to exceed their specified range by 10 %. The scaling of the quantity remains as before; the extra range is used for additional measurement range in the wet end.

**AOVER** [*ON/OFF*]  
<cr>

### Example:

```
>aover on
: ON
>
```

## Serial Line Output Commands

### Start Measurement Output

Use the **R** command to start the continuous outputting of measurement values as an ASCII text string to the serial line. The format of the measurement message is set with the **FORM** command.

**R**<cr>

### Example:

```
>r
aw= 0.261 T= 23.8 'C H2O= 15 ppm
>
```

You can change the format of the output with the following commands:

- Outputting interval can be changed with the **INTV** command.
- Output message format can be changed with the **FORM** command.

### Stop Measurement Output

Use the **S** command to end the RUN mode. After this command all other commands can be used. You can also press the **Esc** button or reset the transmitter to stop the outputting.

**S**<cr>

See **SMODE** command on page 32 to change the default (power-up) operation mode.

## Set Output Interval

Use the **INTV** command to set or display the output interval.

```
INTV [n xxx]<cr>
```

where

*n* = time interval = 0 ... 255  
*xxx* = time unit = "S", "MIN", or "H"

### Example:

```
>intv 1 min  
Output interval: 1 MIN  
>
```

The shortest output interval (with *n* = 0) is approximately one second due to the internal measurement cycle.

## Output Reading Once

Use the **SEND** command to output the reading once in STOP mode.

The output format depends on which parameters the transmitter can output.

```
SEND [aa]<cr>
```

where

*aa* = Transmitter address (0 ... 99). Must be specified if the transmitter is in POLL mode, and a line has not been opened using the **OPEN** command.

### Example:

```
>SEND  
T= 25.2 'C aw= 0.299 H2O= 19 ppm RS= 29.9 %  
>
```

# Troubleshooting Commands

## Display the Currently Active Errors

Use the **ERRS** command to display the currently active transmitter error states. Possible errors and their causes are listed in Table 8 on page 49.

**ERRS**<cr>

### Example:

```
>errs  
No errors  
>
```

## Test Analog Outputs

The operation of the analog outputs can be tested with the **ATEST** command by forcing the output to a given value which can then be measured with calibrated multimeter. The command uses the currently selected analog output types for the channels (voltage or current) so you do not have to specify the unit.

Before testing, you can verify the currently set analog output modes using the **AMODE** command. After testing the output, give the **ATEST** command again to exit the test mode.

**ATEST** [xxx yyy]<cr>

where

xxx           = Channel 1 output value (V or mA)  
yyy           = Channel 2 output value (V or mA)

The output shows the test values of the analog channels, and diagnostic information that may be useful to Vaisala Service if there is a problem with the analog outputs.

### Example:

```
>atest 1 15  
  1.00       2660  
 15.00      19425  
>  
  
>atest  
  0.00        79  
  0.00      20110  
>
```

## Other Commands

### Opening the Transmitter in POLL Mode

Use the **OPEN** command to connect to a transmitter that is in POLL mode.

```
OPEN [aa]<cr>
```

where

*aa* = address (0 ... 99)

**Example:**

```
open 0  
MMT162 0 line opened for operator commands
```

### Closing the Connection to a Transmitter in POLL Mode

The **CLOSE** command closes the connection to the transmitter.

```
CLOSE<cr>
```

**Example:**

```
>close  
line closed  
>
```

## Display Command List

Use the **HELP** command to list the available commands.

**HELP**<cr>

**Example:**

```
help
?
??
ACAL
ADDR
ADJD
AERR
ALARM
AMODE
AOVER
ASEL
ATEST
CDATE
CLOSE
CRH
CT
CTEXT
ERRS
FILT
FORM
FRESTORE
HELP
INTV
L
LED
OIL
OILI
OPEN
PCOMP
PRES
R
RESET
SDELAY
SEND
SERI
SMODE
UNIT
```

## Reset Transmitter

When the **RESET** command is given, the transmitter will restart as if it had just been powered on. All transmitter settings are retained. The serial line mode of the transmitter will be set to the mode that was set using the **SMODE** command.

```
RESET<cr>
```

## Restore Factory Settings

Use the **FRESTORE** command to restore the factory settings to the transmitter. All user settings will be lost.

```
FRESTORE<cr>
```

## ppm Conversion

### MMT162 ppm Conversion for Transformer Oils

Traditionally, moisture in transformer oil is measured by using ppm units. The ppm output shows the average *mass concentration of water* in oil.

The moisture and temperature transmitter MMT162 has an option for ppm-output provided that this has been notified when placing the order for the transmitter. Vaisala has this conversion readily available for mineral transformer oils.

## Conversion Model with Average Coefficients

The conversion model of the MMT162 is based on the average water solubility behaviour of transformer oils. The ppm-output is calculated as follows:

$$ppm = aw \times 10^{((A/T+273.16)+B)}$$

where

aw = water activity

A,B = coefficients (average/oil-specific)

T = temperature (°C)

Generally, measurements with MMT162 give accuracy better than 10 % of the reading. If additional accuracy is needed, refer to section Conversion Model with Oil-specific Coefficients below.

## Conversion Model with Oil-specific Coefficients

For additional accuracy, oil-specific conversion model can be used both for mineral and silicon based oils. An oil sample has to be sent to Vaisala for modelling. As a result, the specific coefficients (A and B, see formula 1) for the transformer oil are determined by Vaisala. For additional information, please contact Vaisala.

The determined coefficients of the transformer oil can be programmed to the MMT162 by Vaisala or by a user according to the instructions presented in this chapter.

<b>NOTE</b>	Conversion model with oil-specific coefficients is always needed for <b>silicone based oils.</b>
-------------	--

## Setting Oil Coefficients Using Serial Line

If the ppm conversion and oil-specific coefficients have been programmed at Vaisala, you do not have to set the conversion coefficients.

If you have defined the coefficients or separately received from Vaisala the oil-specific coefficients A and B, related to your own oil type, the coefficients can be set to the software of MMT162 by using serial line.

### OIL

Use the serial line command **OIL** to display oil-specific parameters for ppm conversion. With **OILI** command you can set new oil parameters.

#### Example:

```
oil
Oil[0]   : -1.66269994E+03
Oil[1]   :  7.36940002E+00
Oil[2]   :  0.00000000E+00
```

where

Oil [0] corresponds to parameter A  
Oil [1] corresponds to parameter B  
Oil [2] Corresponds to parameter C

## Determination of Oil-Specific Coefficients

The equation of the ppm calculation is:

$$\text{ppm} = \text{aw} * 10^{(B+A/T)}$$

With the following procedure the coefficients A and B can be defined for the equation:

$$\text{LOG}(\text{PPM}_{\text{sat}}) = B + A/T$$

## Equipment needed:

- Apparatus for determining water content ( for example, coulometric titrator and e.g. magnetic stirrer.)
- Oil test station:
  - a temperature test chamber
  - for example, a conical flask (1L) sealed by PTFE stopper with an inlet for a moisture probe
  - MMT162 by Vaisala
  - magnetic stirrer.

## Procedure:

1. Define the water content of the oil sample with the titration. Use the oil moisture level that is close to real conditions in the process.
2. Measure the water activity of this sample with MMT162 at two temperatures that differ at least 20 °C. Follow the measurement stabilization illustrated by the graph.

**NOTE**

The sample has to be sealed very carefully i.e. not to be in contact with ambient air, which would change the water content.

**NOTE**

If the oil sample is very dry and the temperatures are close to each other, it may cause inaccuracy to the calculation model. In order to get the best possible performance it is recommended to use oil conditions that represent real conditions in application. Recommended values for sample are  $a_w$  approx. 0.5 at 20 °C.

3. Define the correlation between  $a_w$ , T and PPM (w/w) from the measured values. Calculate A and B according to the following example.

$$A = \frac{\text{LOG}(PPM_{sat}[T2]) - \text{LOG}(PPM_{sat}[T1])}{1/(T2) - 1/(T1)}$$

$$B = \text{LOG}(PPM_{sat}[T1]) - A/T1$$

**Example:**

measured water content 213 ppm

T (°C)	aw	ppm <sub>saturation</sub>
24.1	0.478	213/0.478 = 445.6067
57.6	0.188	213/0.188 = 1132.979

$$A = (\text{LOG}(1132.98) - \text{LOG}(445.607)) / (1/(57.6 + 273.16) - 1/(24.1 + 273.16)) = -1189.4581$$

$$B = \text{LOG}(445.607) - (-1189.4581) / (24.1 + 273.16) = 6.6503583$$

Assumptions:

The isotherm of water activity versus water concentration is linear and the solubility curve has the form of the given equation.

This page intentionally left blank.

## CHAPTER 5

# MAINTENANCE

This chapter provides information that is needed in basic maintenance of the product.

## Cleaning

Clean the transmitter enclosure with a soft, lint-free cloth moistened with mild detergent.

Clean the sensor before storing the MMT162 probe and before calibration. For cleaning the the probe you need instrument air and heptane ( $C_7H_{16}$ ) liquid. If heptane is not available, you can also use diesel oil or petrol. Dry with instrument air to prevent oxidation of the oil on the sensor. The oxidation of the oil on the sensor can cause extended response times or drifting.

1. Blow the probe head (with filter) with instrument air to remove the remains of oil.
2. Immerse the probe head into heptane liquid and rinse out the oil (for one minute maximum).
3. Dry the probe head with instrument air. In case you are going to calibrate the probe, remove the filter and dry the sensor with instrument air. Check that the sensor looks clean.

**NOTE**

Do not immerse the sensor in any polar solvents, for example ketones or alcohols.

## Changing the Probe Filter

1. Remove the filter from the probe.
2. Install a new filter on the probe. When using the stainless steel filter (for oil and fuel cell), take care to tighten the filter properly (recommended force 130 Ncm).

New filters can be ordered from Vaisala, see section Spare Parts and Accessories on page 61.

## Changing the Sensor

If you need to change the sensor on your MMT162, send it to Vaisala where the sensor will be changed for you.

## Error States

MMT162 has the following states that indicate a problem with the probe:

- Analog 4 - 20 mA current output at 0 mA
- Analog voltage output at 0 V
- Serial line outputs asterisk characters (\*\*\*)

The asterisk characters on the serial line may also appear during the start-up procedure.

You can also check the error message via the serial interface by using the **ERRS** command. In case of constant error, please contact Vaisala; see section Vaisala Service Centers on page 50.

**Table 8 Error Messages**

<b>Error Message</b>	<b>Action</b>
Voltage error	
T meas error	Internal error, can be caused by damage to the sensor.
F meas error	Internal error, can be caused by damage to the sensor.
Voltage too low error	Supplied operating voltage is too low for reliable operation.
Voltage too low for mA output	Supplied operating voltage is too low for reliable operation of the analog current output.
Voltage is too low for V output	Supplied operating voltage is too low for reliable operation of the analog voltage output.
Ambient temperature error	Ambient temperature out of operating range (probably too hot).
Program flash check sum error	Internal error
Parameter check sum error	Internal error
INFOA check sum error	Internal error
SCOEFS check sum error	Internal error
CURRENT check sum error	Internal error
Unknown error	

## Technical Support

For technical questions, contact the Vaisala technical support:

E-mail [helpdesk@vaisala.com](mailto:helpdesk@vaisala.com)

Fax +358 9 8949 2790

## Return Instructions

If the product needs repair, please follow the instructions below to speed up the process and to avoid extra costs to you.

1. Read the section Warranty on page 8.
2. Contact a Vaisala Service Center or a local Vaisala representative. The latest contact information and instructions are available from [www.vaisala.com](http://www.vaisala.com). Addresses of the Service Centers are provided in section Vaisala Service Centers on page 50. Please have the following information on hand:
  - serial number of the unit
  - date and place of purchase or last calibration
  - description of the fault

- circumstances in which the fault occurs/occurred
  - name and contact information of a technically competent person who can provide further information on the problem
3. Pack the faulty product in a strong box of adequate size, with proper cushioning material to avoid damage.
  4. Include the information specified in step 2 in the box with the faulty product. Also include a detailed return address.
  5. Ship the box to the address specified by your Vaisala contact.

## Vaisala Service Centers

Vaisala Service Centers perform calibrations and adjustments as well as repair and spare part services. See contact information below.

Vaisala Service Centers also offer accredited calibrations, maintenance contracts, and a calibration reminder program. Do not hesitate to contact them to get further information.

### **NORTH AMERICAN SERVICE CENTER**

**Vaisala Inc.**, 10-D Gill Street, Woburn, MA 01801-1068, USA.

Phone: +1 781 933 4500, Fax: +1 781 933 8029

E-mail: us-customersupport@vaisala.com

### **EUROPEAN SERVICE CENTER**

**Vaisala Instruments Service**, Vanha Nurmijärventie 21 FIN-01670 Vantaa, FINLAND.

Phone: +358 9 8949 2658, Fax: +358 9 8949 2295

E-mail: instruments.service@vaisala.com

### **TOKYO SERVICE CENTER**

**Vaisala KK**, 42 Kagurazaka 6-Chome, Shinjuku-Ku, Tokyo 162-0825, JAPAN.

Phone: +81 3 3266 9617, Fax: +81 3 3266 9655

E-mail: aftersales.asia@vaisala.com

### **BEIJING SERVICE CENTER**

**Vaisala China Ltd.**, Floor 2 EAS Building, No. 21 Xiao Yun Road, Dongsanhuan Beilu, Chaoyang District, Beijing, P.R. CHINA 100027.

Phone: +86 10 8526 1199, Fax: +86 10 8526 1155

E-mail: china.service@vaisala.com

**[www.vaisala.com](http://www.vaisala.com)**

## CHAPTER 6

# CALIBRATION AND ADJUSTMENT

This chapter provides information that is needed in calibration and adjustment of the product.

The MMT162 is fully calibrated and adjusted as shipped from factory. The calibration interval depends on the application. It is recommended that calibration is done always when there is a reason to believe that the device is not within the accuracy specifications.

You can calibrate the MMT162 yourself or send it to Vaisala for calibration. Calibration and adjustment is usually carried out through serial line. One-point calibrations and adjustments can also be done by using an MI70 indicator and Vaisala humidity calibrator HMK15.

Before the calibration, the used sensor needs to be cleaned with instrument air to blow out existing oil or gently first flush with heptane ( $C_7H_{16}$ ) and dry with instrument air to decrease response time, see section Cleaning on page 47.

**NOTE**

It is important to clean the sensor before calibration as the oily sensor can contaminate the salt bath and change the reference condition.

Vaisala HUMICAP<sup>®</sup> hand-held moisture and temperature in oil meter MM70 can also be used for calibration.

## MM70 in Checking and Adjusting

MMT162 can be checked and adjusted by using the MM70. In the field you can check and adjust the probe's reading against the calibrated reference probe of the MM70.

To check the MMT162 transmitter with MM70:

1. Connect the MMT162 to the MM70 indicator with the appropriate connection cable (Vaisala item 219980).
2. Turn on the MM70.
3. Prepare the probe for adjustment by opening the adjustment menu on the MM70 (**Menu** → **Functions** → **Adjustments**)

**NOTE**

Make sure that both probes are stabilized to same conditions so that the temperature readings are the same.

4. Press the **OK** key to start adjustment.

## One-Point Relative Humidity Adjustment

Note that the humidity reference must be at least 50% RH. The MMT162 must be unpowered during stabilization which can take 30 minutes or more.

### Using Serial Line

To adjust the relative humidity:

1. Remove the filter from the probe and insert the probe into a measurement hole of the dry end reference chamber (for example, NaCl: 75 % RH in the humidity calibrator HMK15). Use the adapter fitting.
2. Wait at least 30 minutes for the sensor to stabilize.
3. Connect the MMT162 to a PC, see section Serial Communication on page 23. Then open a terminal program.
4. Enter the **CRH** command and press **ENTER**.

### CRH

5. Type **C** and press **ENTER** a few times to check if the reading has stabilized.

- When the reading is stable, give the reference humidity after the question mark and press **ENTER**.

```
crh
RH :    25.21  Ref1 ?
RH :    25.22  Ref1 ?
RH :    25.22  Ref1 ? 30.1
Press any key when ready ...
RH :    25.19  Ref2 ?
OK
```

- OK** indicates that the adjustment has succeeded and the new calibration coefficients are calculated and stored.
- Take the probe out of the reference conditions and replace the filter.

## Using MI70

To adjust the relative humidity:

- Connect MI70 to MMT162.
- Turn MI70 on.
- On the MI70, go to **Menu** → **Functions** → **Adjustments**



Figure 14 Main Menu

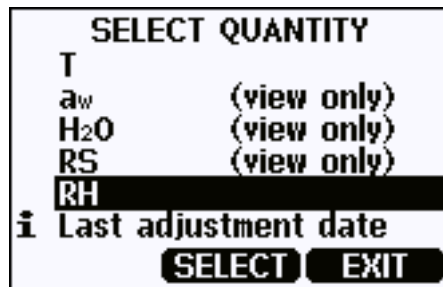

Figure 15 Functions Menu

- Follow the instructions given on the display.



- Select RH from the list and press **Select**.



- When adjusting relative humidity, you need to check the environment settings before making the adjustment.

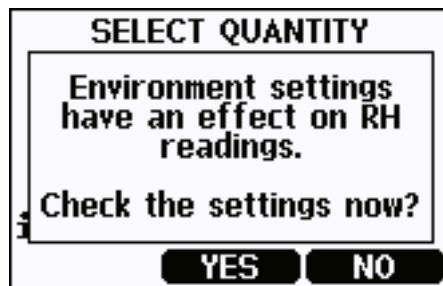

7. In adjustment mode, enter the correct reference value and then exit by pressing **Back**.

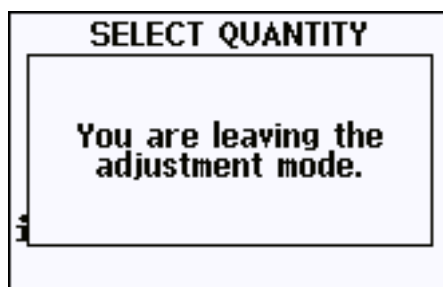

## One-Point Temperature Adjustment

The MMT162 must be unpowered during stabilization which can take 30 minutes or more.

### Using Serial Line

1. Remove the probe filter and insert the probe into the reference temperature.
2. Enter the command **CT** and press **ENTER**.

### CT

3. Type **C** and press **ENTER** a few times to check if the reading is stabilized. Let the reading stabilize, give the reference temperature after the question mark and press **ENTER** three times.

#### Example:

```
ct
T   :   22.03  Ref1 ?
T   :   22.03  Ref1 ?
T   :   22.03  Ref1 ? 25.0
Press any key when ready ...
T   :   22.02  Ref2 ?
OK
```

4. **OK** indicates that the calibration has succeeded.
5. Take the probe out of the reference conditions and replace the filter.

## Using MI70

To adjust temperature:

1. Connect MI70 to MMT162 via connector II.
2. Turn on MI70.
3. On the MI70 display, go to **Menu** → **Functions** → **Adjustments**.

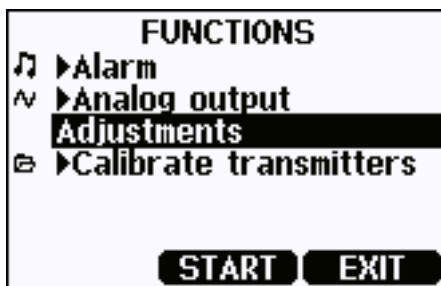

4. Follow the instructions given on the MI70 display.

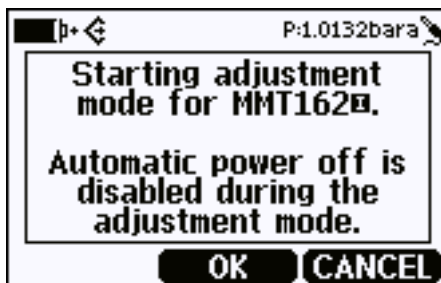

5. Select **T** from the list and press **Select**.

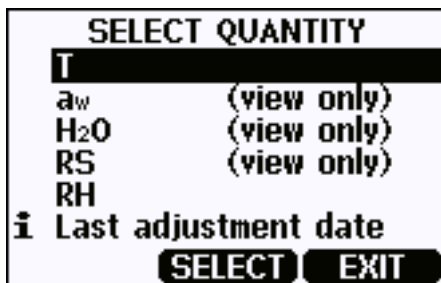

6. Select 1-point adjustment and press **Select**.

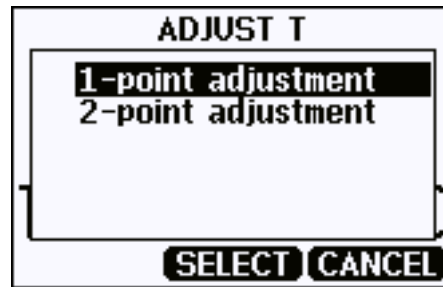

7. In adjustment mode, enter the correct reference value and then exit by pressing **Back**.



8. After you have exited the adjustment mode, MI70 confirms it by displaying the message below.

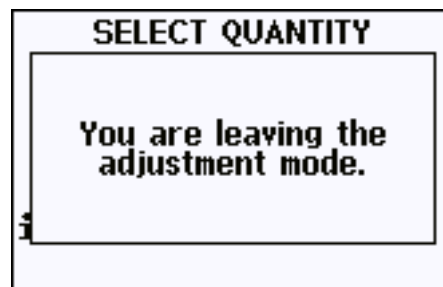

## Analog Output Adjustment

In the analog output calibration the analog output is forced to the following values:

- current output: 2 mA and 18 mA
- voltage output: 10 % and 90 % of the range

Connect MMT162 to a calibrated current/voltage meter in order to measure either current or voltage depending on the selected output type.

To calibrate analog output, see section Calibrate Analog Output on page 34.

## CHAPTER 7

# TECHNICAL DATA

This chapter provides the technical data of the product.

## Measured Values

### Water activity

Measurement range	0 ... 1 (@-40 ... +180 °C/ -40 ... +356 °F)
Accuracy (including non-linearity, hysteresis and repeatability) When calibrated against salt solutions (ASTM E104-85):	
0 ... 0.9	± 0.02
0.9 ... 1.0	± 0.03
Response time in oil flow (typical) with stainless steel filter	< 1 min. (dry-wet)
Sensor	HUMICAP®

### Temperature

Measurement range	-40 ... +80 °C (-40 ... +176 °F)
Accuracy at +20 °C (+68 °F)	± 0.2 °C (± 32.36 °F)
Typical temperature dependence of electronics	± 0.005 °C/°C (± 0.003 °F/°F)
Sensor	Pt 100 RTD 1/3 Class B IEC 751

## Operating Environment

Operating temperature	-40 ... +60 °C (40 ... +140°F)
Pressure range	
metal version	up to 200 bar
plastic version	up to 40 bar
Complies with EMC standard	EN61326-1:1997+ Am1:1998 + Am2:2001 Industrial environment
Oil flow	some flow recommended

## Inputs and Outputs

Minimum operating voltage	
with current output	22...28 VDC
with voltage output	16...28 VDC
with RS-485	14...28 VDC
Supply current	
normal measurement	20 mA + load current
External load for	
current output	max. 500 Ohm
voltage output	min. 10 kOhm
Analog outputs (2 standard)	
current output	0 ... 20 mA, 4 ... 20 mA
voltage output	0 ... 1 V, 0 ... 5 V, 0 ... 10 V
Accuracy of analog outputs at 20 °C	± 0.05 % full scale
Temperature dependence of the analog outputs	
current	± 0.005 %/°C full scale
voltage	
Digital output	RS-485

## Mechanics

Interface cable connector	M8 series 4-pin (male) with plug (female) with straight or 90° angle connector
Probe cable diameter	5.5 mm
Probe cable lengths	
snap-on cable	2 m
shielded cables	0.32 m, 3 m, 5 m and 10 m
90° angle cable	2 m and 5 m
LED cable	3 m
Housing material	
metal	AISI 316L
plastic	PPS + 40% GF
Housing classification	IP 65 (NEMA 4)
Mechanical connections	
Option 1	ISO G1/2"
Option 2	NPT 1/2"
Weight	
Metal with ISO thread	200 g
Metal with NPT thread	200 g
Plastic with ISO thread	65 g

## Spare Parts and Accessories

<b>Description</b>	<b>Order code</b>
Connection cable for MM70	219980
USB serial interface cable	219690
CH1 signal + Ch2 LED cable, M8 threaded connector	MP300LEDCBL
Sealing ring set (copper) ISO G1/2, 3 pieces	221524SP
Sealing ring set (U-seal) ISO G1/2, 3 pieces	221525SP
Protection plug	218675
ISO 1/2" plug	218773
NPT 1/2" plug	222507
110 ... 240 VAC external power supply	POWER-1
Calibration adapter for HMK15	211302SP
<b>Filters</b>	
Stainless steel grid filter	221494SP
Stainless steel grid filter for high flow (> 1 m/s)	221493SP
<b>Analog/RS-485 output cables</b>	
2 m (6,5 ft) cable, M8 snap-on connector	211598
0.32 m (1 ft) shielded cable, M8 threaded connector	HMP50Z032
3 m (9.8 ft) shielded cable, M8 threaded connector	HMP50Z300
5 m (16.4 ft) shielded cable, M8 threaded connector	HMP50Z500
10 m (32.8 ft) shielded cable, M8 threaded connector	HMP50Z1000
2 m (9.8 ft) shielded cable, 90° angle connector	221739
5 m (16.4 ft) shielded cable, 90° angle connector	221740
<b>Sampling cells (available only for ISO G1/2")</b>	
Sampling cell	DMT242SC
Sampling cell with 1/4" male Swagelok connectors	DMT242SC2

## Dimensions in mm (inches)

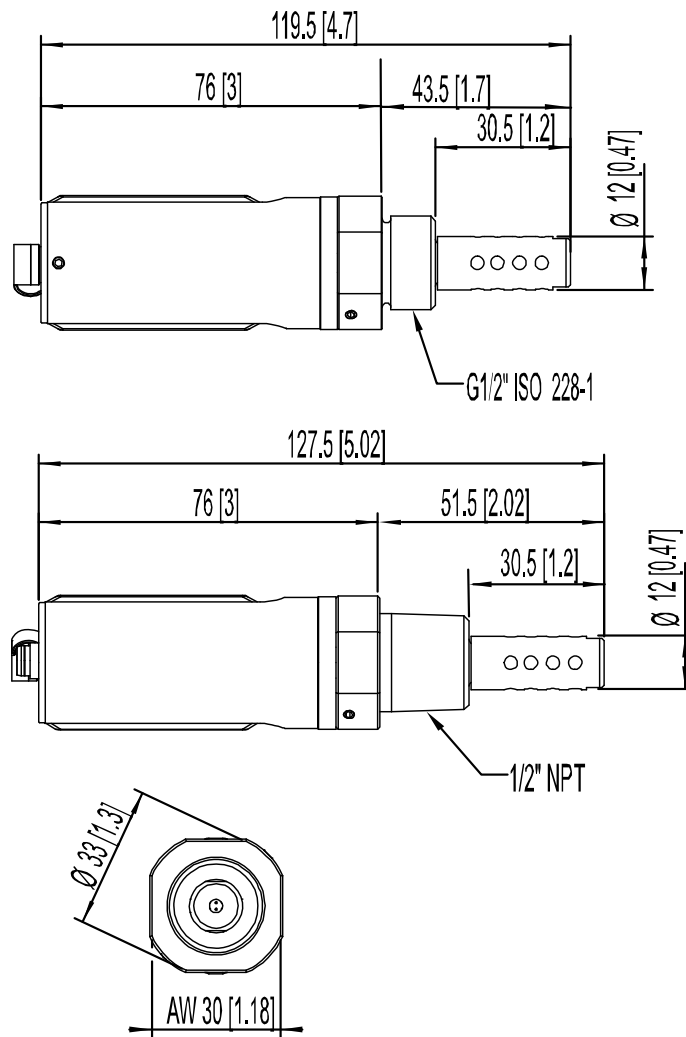

0804-084

**Figure 16 Metal Housing Transmitter Dimensions**

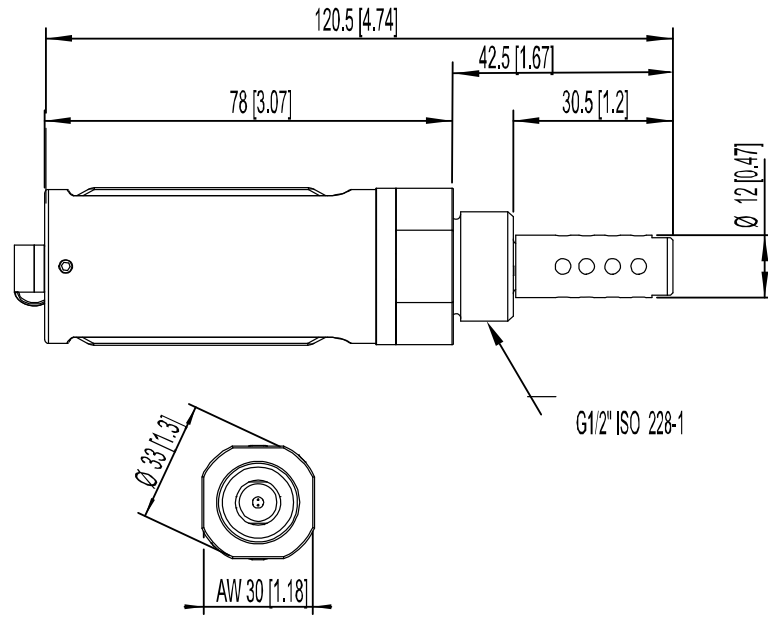

0804-085

**Figure 17 Plastic Housing Transmitter Dimensions**



[www.vaisala.com](http://www.vaisala.com)

