

# Lithium battery manufacturing process

**Lithium battery manufacturing is a sensitive process, where the materials must be protected from moisture. The demanding environment requires a dewpoint instrument with excellent chemical durability. Vaisala DRYCAP® Dewpoint Transmitters meet the high standards.**

The lithium battery manufacturing process requires thorough dry air management in order to prevent unwanted chemical reactions and defects on product quality. Most of the processes are situated in dry rooms where optimum conditions can be maintained. The typical dewpoint range is -50...-40 °C. The environment is demanding in terms of chemicals evaporating from the materials, such as manganese dioxide, lithium etc.

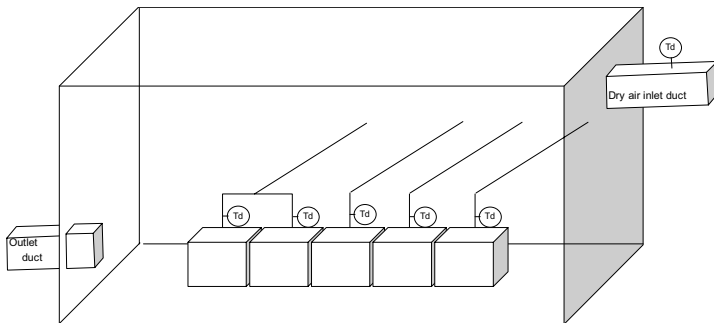

Dewpoint instruments can be installed at the inlet of each process on the supply gas line directly or by using a sampling cell or a ball valve. All Vaisala DRYCAP® dewpoint instruments have standard ISO or NPT threads which can be installed directly to the duct.

Vaisala sampling cells are designed to provide the user with easy installation. They are available with threaded connections to accept a wide variety of fittings, or with welded compression fittings to accommodate 6mm or 1/4"

tubing. A ball valve installation allows the dewpoint probe to be installed or removed from a process without process shut- down.

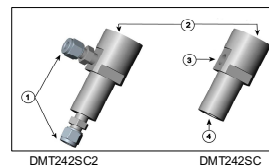

Number refer to Figure1 :  
 1: Male pipe weld connector Swagelok 1/4"  
 2: Instrument probe  
 3: G1/4"  
 4: G3/8"

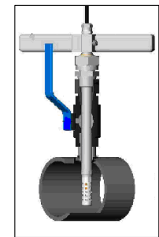

Figure2 : Ball valve installation

## Dewpoint measurement with DRYCAP® technology

Dewpoint temperature is generally the preferred method to measure water vapor of a dry gas. In such conditions the changes in relative humidity are too small to control, but the changes in water vapor concentration produce a measurable change in dewpoint temperature.

Vaisala Dewpoint temperature products incorporate the DRYCAP® capacitive polymer sensor. The main features are :

- Withstands a high humidity environment ... Vaisala DRYCAP® sensors are not damaged by an unexpected high humidity situation.
- Fast response time ... Accurate data is always available, even when the process is changing fast.
- Patented Auto-calibration function ... automatic offset correction function maintains good accuracy and long-term stability. We specify accuracy  $\pm 2^{\circ}\text{C}$  down to  $-60^{\circ}\text{C}$ , and recommend a two year calibration interval.
- Other unique functions ... Sensor purge function maintains good conditions on the sensor by purging unknown chemicals from the polymer. The sensor warming function heats the sensor and prevents condensation from forming on it.